



Head Office/ Taiwan:

**TJR Precision Technology Co., Ltd.**

TEL: (886) 4-2562-1267 FAX: (886) 4-2562-1297 / (886) 4-2562-1198  
No. 178, Sec. 1, Shenlin Rd., Daya Dist., Taichung City 428007, Taiwan (R.O.C.)  
Web: www.tjr.com.tw e-mail: tjr@tjr.com.tw

Welcome to the download area of the website for E-catalog.



**Jiangsu, Jin Tan Jia Precision Machinery Co., Ltd.**

TEL: 0512-5781 8756  
No. 19, JinYang East Road, LuJia Town, Kunshan City, Jiangsu, China, 215334

**Shanghai Tan Jia Machinery Equipment Ltd.**

TEL: (86) 21-6806-0545-6 FAX: (86) 21-6806-0547  
e-mail: zhuhongmei29@163.com



**Japan, Masaki Precision Machinery Co., Ltd**

5-15-41 Higashimichinobe, Kamagaya-shi, Chiba 273-0103, Japan  
〒273-0103 千葉県鎌ヶ谷市東進野辺5丁目15-41

TEL: +81-80-6910-1602 E-mail: tjr@tjr.com.tw

※Contact: 鈴木 総理 E-mail: masaki\_eri0919@ymail.ne.jp



**Thailand, TJR Precision Machinery Co., Ltd**

Number 1/4 Moo 5, Rajana Industrial Estate, Project 1, Khan Ham Subdistrict,  
Uthai District, Phra Nakhon Si Ayutthaya Province 13210, Thailand.  
E-mail: tjr@tjr.com.tw



**India, TJR Precision Technology Private Limited**

Plot No. I-11, Central Avenue Road, Mahindra Industrial Park,  
Peruvoyal Village - 601206 Gummidipoondi Taluk, Tiruvallur Dist, India.  
E-mail: tjr@tjr.com.tw

2026-06 The 14<sup>th</sup> version TJR Precision Technology Co., Ltd.  
owns the related right of modification.



APP (iOS)



APP (Android)



We Chat



E - Catalog



Website



**TJR Precision Technology**

Rotating Positivity Forward www.tjr.com.tw The 14<sup>th</sup> Edition

# TJR Precision Technology

Rotating Positivity Forward



**TJR Taiwan** – Taichung headquarters  
established in 2009



**LV TJR China** – Suzhou factory  
established in 2015



**in TJR India** – Chennai factory  
registered in 2021



**Masaki Japan** – Tokyo factory  
registered in 2022



**th TJR Thailand** – Bangkok factory  
registered in 2023

## Company Profile

TJR Precision Technology was established in December 2009, specializing in the manufacturing of high-precision key components for CNC machine tools. Our main products are ultra-high precision CNC rotary tables (4<sup>th</sup> axis and 5<sup>th</sup> axis), which are widely used in aerospace, high-tech electronics, automotive parts manufacturing, and various other machinery industries.

With our outstanding R&D capabilities, we provide high-precision, high-efficiency, and reasonably priced customized professional services to meet the needs of both domestic and international customers.

Our core values—integrity, responsibility, and innovation—drive our commitment to long-term, sustainable development and business longevity.

Guided by the spirit of “Rotating Positivity Forward”, we strive to build a corporate culture rooted in optimism, accountability, and continuous progress.



There are **three common transmission mechanisms** of rotary table as bellow:  
You can find **all types of mechanism in TJR.**

### 3 Transmission Mechanisms

**A**



Driven by **roller gear cam**  
(speed: **80 rpm**)



Strength:

- ① Almost no backlash during the clockwise / anti-clockwise rotation
- ② **Almost no abrasion** for the transmission mechanism
- ③ High speed

**B**



Driven by **worm & worm gear**



Strength:

- ① The major and cost-effective solution
- ② Easy to adjust backlash after some abrasions



Strength: **a mill / turn component**

- ① If the moving column vertical machining center or drilling & tapping center is equipped with our table, it can make the machine work as a **horizontal** or **vertical lathe** concurrently.
- ② The super high speed of rotary axis: **2000 rpm**.
- ③ Truly **zero backlash** during the clockwise / anti-clockwise rotation.
- ④ Truly **zero wear** for the transmission mechanism.
- ⑤ Long-lasting high precision  
(The actual precision depends on the selected angle encoder)

**C-1**

Driven by **Super high speed direct drive motor**  
(super high speed: **2000 rpm**)



Strength:

- ① Truly **zero backlash** during the clockwise / anti-clockwise rotation.
- ② Truly **zero wear** for the transmission mechanism. (**No abrasion at all**)
- ③ High speed: **200 rpm**
- ④ Long-lasting high precision.  
(The actual precision depends on the selected angle encoder)

**C-2**

Driven by **direct drive motor**  
(speed: **200 rpm**)



### 1 Workpiece material :

- A : For materials like aluminum and copper, it is OK to select AR series (Pneumatic brake)
- B : For materials like cast iron and steel, it is OK to select HR series (Hydraulic brake) or HI series (Hirth coupling Hydraulic brake)

### 2 Workpiece accuracy requirement :

- A : For accuracy within 20 sec, select AR series (as rotary table for any angle)
- B : For accuracy within 15 sec, select HR series (as rotary table for any angle)
- C : For accuracy within 10 sec, the retrofitting of angle encoder can be considered; but the angle encoder costs more. If the processing only occurs at fixed angles, HI series ( $\pm 5$  sec can be achieved) can be considered; however, the HI series cannot be used for continuous cutting, as it only works at fixed angles of multiple of  $1^\circ$  or  $5^\circ$  (see page 38)

### 3 Workpiece shape and size :

- A : If it is in the shape of round bar, please purchase the 3-jaw chuck and the center tailstock additionally. (as below Dia. ① shows) When choosing the 3-jaw chuck, note that its outer diameter should not exceed the table diameter. Please see page 76 for the grip range of the chuck.
- B : If of odd shapes and more than two workpieces are processed at once (see page 75), then purchase support table additionally. (as below Dia. ② shows) [For L-block, base plate and middle plate (connection plates), please have them manufactured by fixture suppliers].
- ※ When using middle plate, please note to limit its width to the max. table diameter.

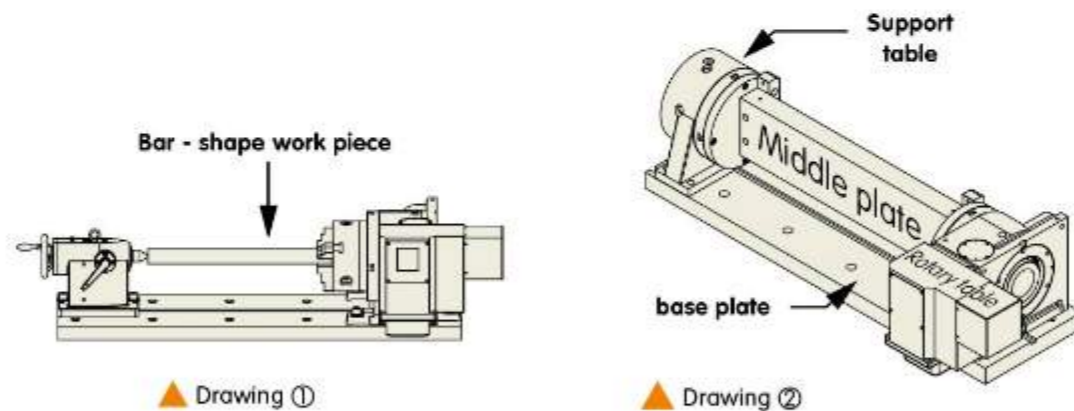

### 4 Max. load :

Verify if the rotary table can withstand the load of workpiece and then add up the weights of predetermined rotary table, tailstock, L-block, middle plate, base plate, workpiece and fixture to see if the total load which the machine can withstand is exceeded. If overweighed, check the material of workpiece first. If the material is aluminum alloy or other light material but you are forced to select a larger rotary table due to its too long details in shapes which require over-large radius of rotation, please feel reassured to select the rotary table of a next smaller size. Fit raiser blocks to lift the workpiece so as to accommodate the radius of rotation whereby to reduce the total weight and the cost.

### 5 Y axis interference :

- First, verify whether the selected rotary table interferes when it is placed on the work table of the machining center. With the Y axis of the vertical machining center moved to the origin, please measure
- A : the distance between central groove of the worktable and the sheet metal of the machine's slide door [Ex: assuming 450mm remains]
  - B : the distance between the centerline of rotary table and the end of motor cover (excluding the wiring box) [Ex: 420mm in HR255-R as below Dia. ③ shows]

If the "B" distance is less than the "A" distance, it is certain that the rotary table will not collide with the sheet metal of the slide door. [Ex: 420mm < 450mm; thus it's ok to select HR255-R] If not, please change to sheet metal cover reduction version of TJR rotary table. [Ex: only 346mm in HR255-N as below Dia. ③-1 shows]

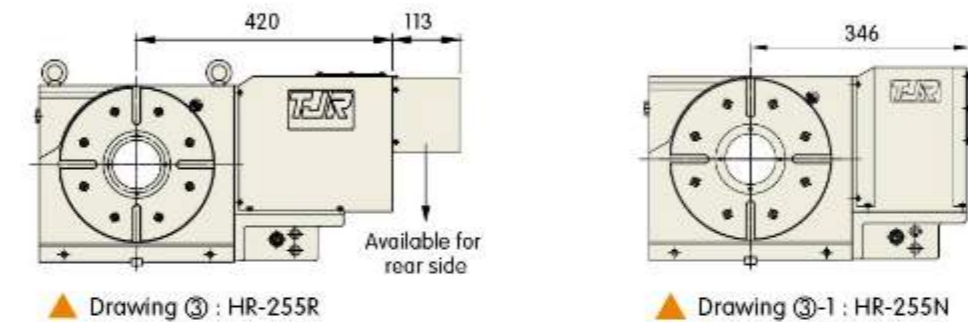

### 6 Verify the available room for placing the workpiece :

Please measure the length of working table of the machine to verify that it is not 200 mm smaller than base plate. It is the maximal allowed protrusion for the base plate of all models to stand out by 100mm on each side of the working table. For example: Assuming the length of working table of the machine is 950mm. (as below Dia. ④ shows) If HR255-N rotary table, RTH-255 support table, and middle plate are selected, then it is determined that 700 mm in "E" middle plate is available for workpiece. (see data sheet on page 75) By the same principle, it's 1148mm in "B" base plate. In this case, it's acceptable since it is only 198 mm larger than machine's working-table. As for the space "E", thickness "J" and width "H", they are advised not to exceed the set values in our specification (as data sheet on page 71).

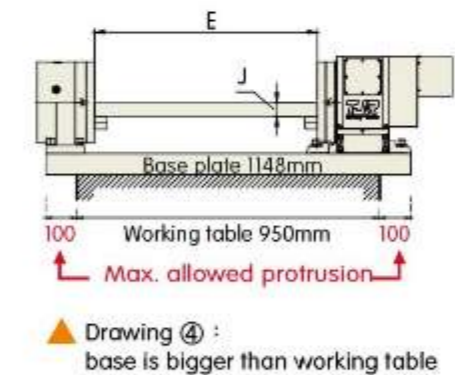

### 7 Important notices :

When purchasing rotary table, support table, and cradle-type fixture (as below Dia. ⑤ shows), it is necessary to advise us if the arm (A) has overtaken the table radius and caused off-center process. Otherwise, the worm wheel will be worn out quickly. (The longer the arm (A) is, the more it's against common sense and normal practice) We shall not be responsible if you fail to advise so.

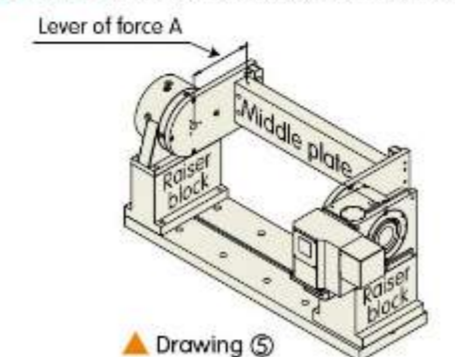

### 8 "Reserved interface for the forth axis" :

The so-called "reserved interface for the forth axis" refers to all the small hardware or PLC software necessarily reserved for the fourth axis on the machine as well as refers to five main components including ① rotary table ② 4<sup>th</sup> axis motor ③ shielded power & feedback cables ④ unshielded power & feedback cables, and ⑤ 4<sup>th</sup> axis amplifier. (as below Dia. ⑥ shows)

- (A) If the machine comes with those reserved interfaces for the fourth axis, there is no problem at all to retrofit the fourth axis of the same system for **four-axes simultaneous contouring**.
- (B) If the machine does not come with those reserved interfaces for the fourth axis, the **single-axis controller (SAC)** we provide (as below Dia. ⑦ shows) can be used to retrofit the fourth axis. However, such single-axis controller does not interlock with any of X, Y and Z axes in the machine. In other words, the other three axes can not be moved unless the fourth-axis motion is complete.

Drawing ⑥ 5 main components of the 4<sup>th</sup> axis

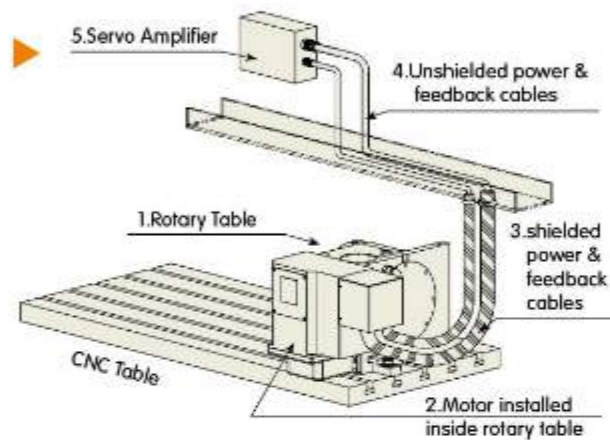

### 9 Application for single axis controller ( SAC ) :

▼ Drawing ⑦

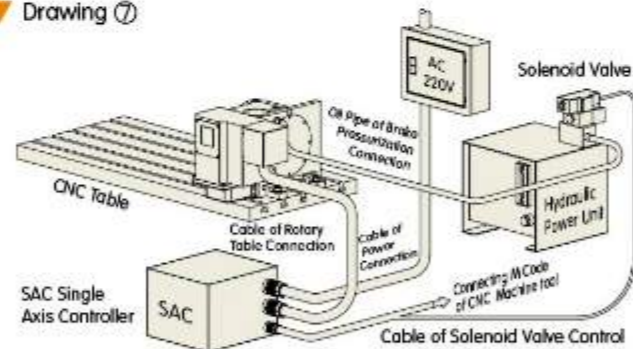

★ With a reserved M Code in the machine center, TJR SAC single axis controller or AIC hydraulic controller can be easily installed, **no matter which brand** of control system is used.

### 10 While using AR series rotary table (pneumatic brake), please note the following matters :

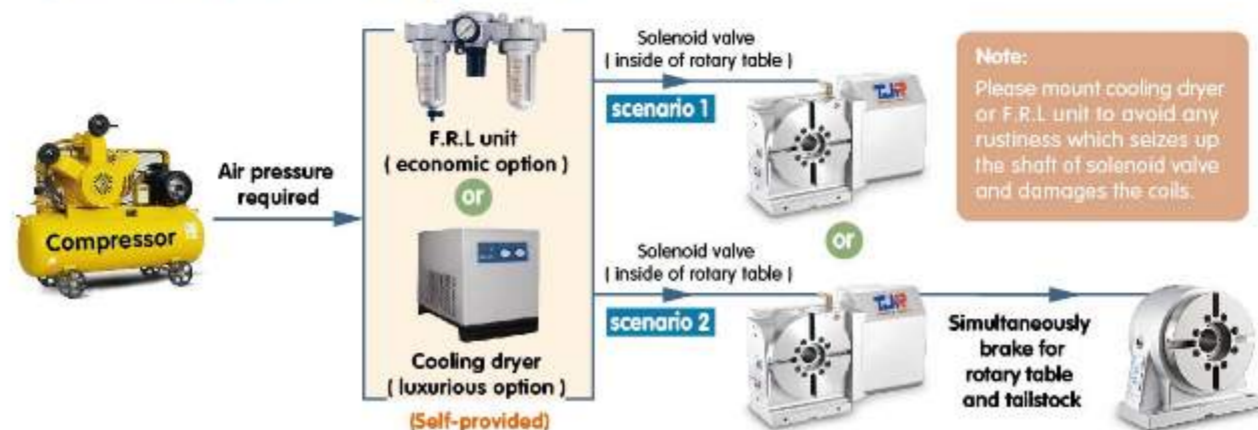

## Product Code

### • 4 - Axis

Model Code	Table Diameter	Hydraulic Brake	Multi-Spindle Series	Motor Mounting & Cover Type
<b>Min. Indexing Angle: 0.001°</b>				
AR	Worm Gear Drive with Pneumatic Brake	H Hydraulic Brake Option (For Ø170-250mm models) (excl. AR-255H)	2W 2-Spindle Coupled	R Right-side Motor; Vertical & Horizontal use
HR	Worm Gear Drive with Hydraulic Brake		3W 3-Spindle Coupled	N Right-side Motor with compact Cover; Vertical use
RC	Roller Gear Cam Drive		4W 4-Spindle Coupled	B Back-side Motor; Vertical use
HRC	Swivel Head with Roller Gear Cam Drive (also applicable for horizontal setup)			L Left-side Motor; Vertical & Horizontal use
HHR	Horizontal Worm Gear Drive with Hydraulic Brake			SP Swivel Spindle Head
MTHR	Manual Tilting 4th Axis with Worm Gear Drive and Hydraulic Brake			FA FANUC Direct Drive Motor
AD	Direct Drive Motor with Pneumatic Brake			
iHHD	Embedded Horizontal Direct Drive Motor with Hydraulic Brake			
<b>Min. Indexing Angle: 1° or 5°</b>				
HI	Hirth Coupling Index Table with Hydraulic Brake			
HHI	Horizontal Hirth Coupling Index Table with Hydraulic Brake			



▲ HR-255

### • 5 - Axis

Model Code	Table Diameter	Rotary Axis Type	Max. Allowable Workpiece Rotation Diameter	Tilting Axis Type	Tilting Axis Features
<b>Min. Indexing Angle: 0.001°</b>					
FAR	Worm Gear Drive with Pneumatic Brake	C Dual-axis Cradle Type	B Tilt Axis: Back-side Motor Type	RC Roller Gear Cam Drive	H Hydraulic Brake Option (For Ø170-250mm models)
FHR	Worm Gear Drive with Hydraulic Brake	S Dual-axis Single-arm Type			
FRC	Roller Gear Cam Drive	SN Dual-axis Single-arm Type (Compact Type)			FA FANUC Direct Drive Motor
FAD	Direct Drive Motor with Pneumatic Brake	A Compact Type			
FHD	Direct Drive Motor with Hydraulic Brake	F Enlarged Faceplate			
FCHR	Dual-pallet Worm Gear Drive with Hydraulic Brake; designed for automatic pallet changers	L Extended Type			
		2W 2-Spindle Coupled			
		HS Ultra-High Speed (for direct-drive motor models)			



▲ FHR-255-2W-RC320

Roller Gear Cam		
Description	Model code	Page
<b>4 - Axis</b> (Min. indexing angle : 0.001°)	 <b>RC Series – Roller Gear Cam Drive</b> RC-170(H) / 210(H) / 250(H) / 255 / 320 / 400	9~14
	 <b>HRC Series – Swivel Head with Roller Gear Cam Drive (also applicable for horizontal setup)</b> HRC-400SP	13~14
<b>5 - Axis</b> (Min. indexing angle : 0.001°)	 <b>FRC Series – Roller Gear Cam Drive</b> FRC-170A / 210L / 255CL / 320CF	15~16
	 <b>FAR / FHR-RC Series – Worm Gear Drive with (Pneumatic / Hydraulic brake)</b> FAR-170-2W / 210-2W FHR-255-2W / 350F-2W / 350CF-2W	17~18
<b>CNC APC Hook Type</b> (for VMC)	 <b>CURC Series – Hook type CNC auto pallet changer (180° to and fro)</b> CURC-500x700	64

Worm & Worm gear		
Description	Model code	Page
<b>4 - Axis</b> (Min. indexing angle : 0.001°)	 <b>AR Series – Worm Gear Drive with Pneumatic Brake</b> AR-125 / 170(H) / 210(H) / 250(H) / 255H	19~24
	 <b>AR Multi-Spindle Series</b> AR-125-2W / 125-3W / 125-4W AR-170-2W / 170-3W / 210-2W / 210-3W	25~28
	 <b>HR Series – Worm Gear Drive with Hydraulic Brake</b> HR-255 / 320 / 320B-2W / 400 / 500 / 630 / 800	29~36
<b>Manual Tilting</b> (Min. indexing angle : 0.001°)	 <b>MTHR Series – Manual Tilting 4th Axis with Worm Gear Drive and Hydraulic Brake (Tilt axis : Manal / Rotary axis : Numerical Control)</b> MTHR-255	35~36
<b>4 - Axis</b> (Min. Indexing Angle : 1° & 5°)	 <b>HI Series – Hirth Coupling Index Table with Hydraulic Brake</b> HI-255 / 320 / 400 / 500	37~40
<b>4 - Axis Horizontal only</b> (HHI : 1° & 5° / HHR : 0.001°)	 <b>HHI Series – Horizontal HI Series</b> <b>HHR Series – Horizontal HR Series</b> HHI-320x320F / 400x400A / 500x500 HHI-630x630 / 800x800 / 1000x1000 HHR-400x400 / 500x500	41~44

Worm & Worm gear		
Description	Model code	Page
<b>5 - Axis</b> (Min. indexing angle : 0.001°)	 <b>FAR Series – Worm Gear Drive with Pneumatic / Hydraulic Brake</b> FAR-125 / 170(H) / 170A(H) / 210(H) FARs-160SN	45~48
	 <b>FHR Series – Worm Gear Drive with Hydraulic Brake</b> FHR-255C / 255CL / 320 / 320C / 400CF / 500C / 650C FHR-400C-540-HR400B / 401C-820-HR400B FHR-400S / 650S-525 / 650S-550 FCHR-650S-550	49~56
<b>CNC APC Tray Type and Rotary Table</b> (for HMC)	 <b>CHI Series – Dual-pallet HI Series for APC.</b> <b>CHR Series – Dual-pallet HR Series for APC.</b> <b>CTH Series – Tray type APC (180° to and fro)</b> <b>CTU Series – Hook type auto pallet changer (180° to and fro)</b> CHI-400 / 500 / 630 · CHR-500 / 630 · CTH-400 / 500 / 630 CTU-400x600 / 500x700	57~63

Direct Drive Motor (D.D.M)		
Description	Model code	Page
<b>4 - Axis</b>	 <b>AD Series – D.D.M with Pneumatic Brake</b> <b>IHHD Series – Embedded Horizontal D.D.M with Hydraulic Brake</b> AD-170 / 261B / 261B-FA IHHD-650	65~66
	 <b>FAD / FHD Series – D.D.M with Pneumatic / Hydraulic Brake</b> FAD-170F / 210F / 211-AD261B FHD-650S-ID650	67~68
<b>5 - Axis</b>	 <b>FAD Series – D.D.M with Hydraulic Brake</b> FAD-300F-HS / 400HS-AD500I / 500FHS-AD500I	69~70

Optional Accessories		
Description	Model code	Page
<b>Tailstock Support</b>	 Support table	71~72
	 Manual tailstock Manual tailstock with Pneumatic / Hydraulic Switching valve	73~74
<b>Bridge Fixture Plate Assembly Rotary Table + Support Table + Fixture Plate + Base Plate + Disc L Block</b>	 Connection Plates	75~76
<b>Other Accessories</b>	 Other Accessories	77~84

## RC Series (Pneumatic / Hydraulic Brake)





### RC - 170 H R



Roller Gear Cam Drive (Min. Indexing Angle: 0.001°)  
 Table Diameter  
 Hydraulic Brake Option  
 Right-side Motor; Vertical & Horizontal use



Use radial & axial bearings Wrap-around Brake

Item / Model	Unit	RC-170(H)R		RC-210(H)R / RC-250(H)R		RC-255R	RC-320R	RC-400R
Table Diameter	mm	Ø170		Ø210 / Ø250		Ø255	Ø320	Ø400
Inner Diameter of Mandrel Sleeve	mm	Ø40H7		Ø40H7		Ø80H7	Ø120H7 x 35 deep	Ø120H7
Diameter of Center Through Hole	mm	Ø40		Ø40		Ø80	Ø105	Ø120
Center Height (Vertical)	mm	135		160		160	210	255
Table Height (Horizontal)	mm	152		152 / 185		200	235	250
Table T-slot Width	mm	12H7		12H7		12H7	14H7	14H7
Guide Block Width	mm	18h7		18h7		18h7	18h7	18h7
Min. Increment	deg.	0.001		0.001		0.001	0.001	0.001
Indexing Precision	sec.	30		30		20	20	20
Repeatability	sec.	6		6		6	6	6
Clamping System : Pne. 0.6[6] / Hyd. 3.5[35]	MPa (kgf/cm <sup>2</sup> )	Pne.	Hyd.	Pne.	Hyd.	Hyd.	Hyd.	Hyd.
Clamping torque ※1	N·m (kgf·m)	304 (31)	491 (50)	304 (31)	491 (50)	687 (70)	1128 (115)	1962 (200)
Servo Motor Type ※3	FANUC	Straight shaft without key		αiF8 / βis8		αiF8 / βis12	αiF12 / βis22	αiF12 / βis22
	MITSUBISHI	Straight shaft without key		HG - 54 / 104		HG - 154	HG - 204	HG - 204
Speed Reduction Ratio	-	1 / 36		1 / 36		1 / 60	1 / 90	1 / 90
Max. Rotation Rate of Table ※2	min <sup>-1</sup>	83.3		83.3		50	33.3	33.3
Allowable Inertia Load Capacity (Vertical)	kg·m <sup>2</sup>	0.63		0.63		1.2	3.15	6.25
Allowable Workpiece Load	Vertical 	kg	75	75	100	150	200	
	with support table	kg	150	150	250	350	500	
	Horizontal 	kg	150	150	250	350	500	
Allowable Thrust Load (with Rotary Table Clamping)	F 	N (kgf)	14225 (1450)	14225 (1450)	19620 (2000)	29430 (3000)	39240 (4000)	
	FxL 	N·m (kgf·m)	1079 (110)	1079 (110)	1472 (150)	2943 (300)	3924 (400)	
	FxL 	N·m (kgf·m)	304 (31)	304 (31)	687 (70)	1128 (115)	1962 (200)	
Driving Torque	N·m (kgf·m)	363 (37)		363 (37)		540 (55)	1050 (107)	1373 (140)
Net Weight (without motor)	kg	44		52 / 62		110	187	-

※1 : If a mechanical brake is not used, this value will correspond to the motor's holding torque.  
 ※2 : The structural limit value, while the actual operating speed will vary depending on the motor.  
 ※3 : For this series of rotary tables, if sudden power outages may occur in the operating environment, motors equipped with a brake function are recommended to prevent displacement or slipping of the rotary or tilting axis during power loss, which could lead to collisions or other accidents.

### RC-170(H)R

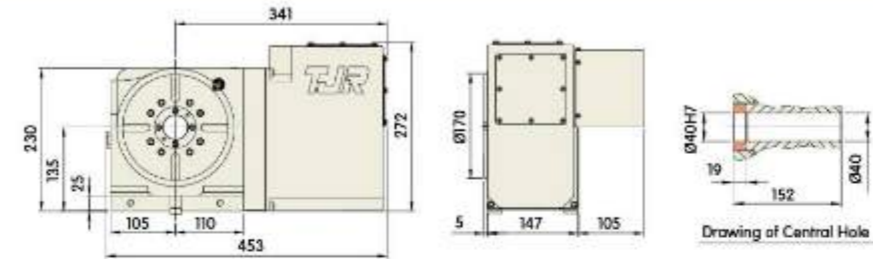

### RC-210(H)R / RC-250(H)R

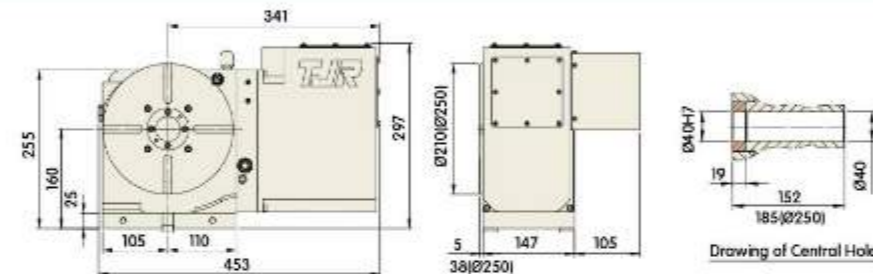

### RC-255R

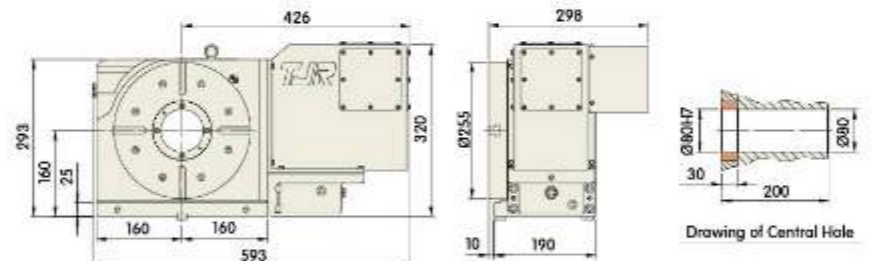

### RC-320R

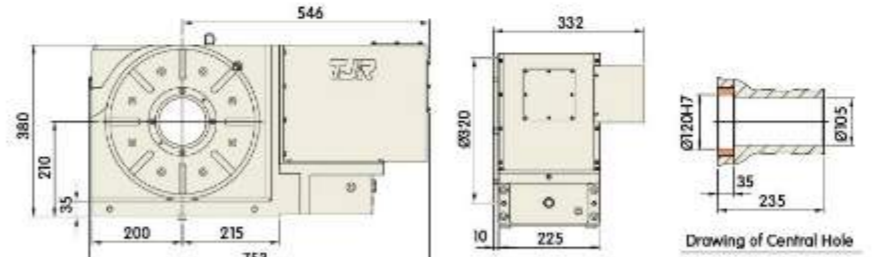

### RC-400R

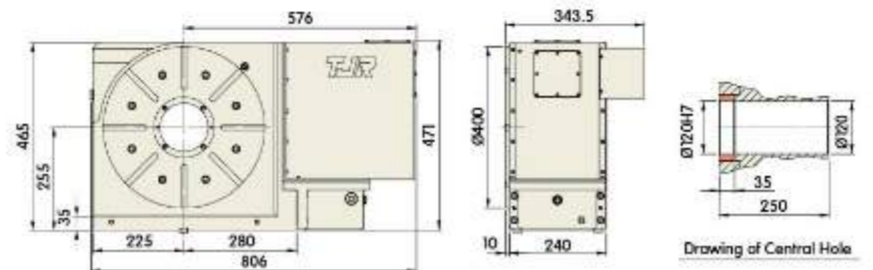



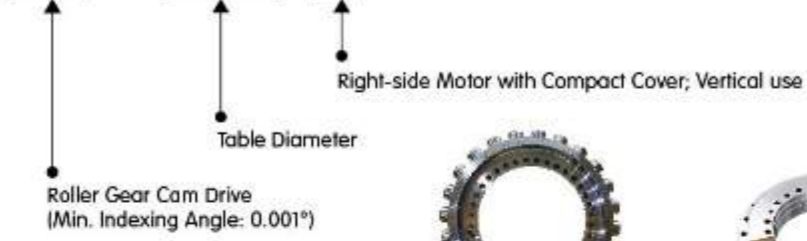

Driven by Roller Gear Cam

## RC Series (Hydraulic Brake)

**RC - 255 N**



Item / Model	Unit	RC-255N	RC-320N	RC-400N	
Table Diameter	mm	Ø255	Ø320	Ø400	
Inner Diameter of Mandrel Sleeve	mm	Ø80H7	Ø120H7 x 35 deep	Ø120H7	
Diameter of Center Through Hole	mm	Ø80	Ø105	Ø120	
Center Height (Vertical)	mm	160	210	255	
Table Height (Horizontal)	mm	200	235	250	
Table T-slot Width	mm	12H7	14H7	14H7	
Guide Block Width	mm	18h7	18h7	18h7	
Min. Increment	deg.	0.001	0.001	0.001	
Indexing Precision	sec.	20	20	20	
Repeatability	sec.	6	6	6	
Clamping System : Hydraulic	MPa (kgf/cm <sup>2</sup> )	35	35	35	
Clamping torque (※1)	N·m (kgf·m)	687 (70)	1128 (115)	1962 (200)	
Servo Motor Type (※3)	FANUC	Straight shaft without key	αiF8 / βis12	αiF12 / βis22	αiF12 / βis22
	MITSUBISHI	Straight shaft without key	HG - 154	HG - 204	HG - 204
Speed Reduction Ratio	-	1 / 60	1 / 90	1 / 90	
Max. Rotation Rate of Table (※2)	min <sup>-1</sup>	50	33.3	33.3	
Allowable Inertia Load Capacity (Vertical)	kg·m <sup>2</sup>	1.2	3.15	6.25	
Allowable Workpiece Load	Vertical 	kg	100	150	200
	with support table	kg	250	350	500
	Horizontal 	kg	-	-	-
Allowable Thrust Load (with Rotary Table Clamping)	F 	N (kgf)	19620 (2000)	29430 (3000)	39240 (4000)
	FxL 	N·m (kgf·m)	1472 (150)	2943 (300)	3924 (400)
	FxL 	N·m (kgf·m)	687 (70)	1128 (115)	1962 (200)
Driving Torque 	N·m (kgf·m)	540 (55)	1050 (107)	1373 (140)	
Net Weight (without motor)	kg	110	187	-	

※1 : If a mechanical brake is not used, this value will correspond to the motor's holding torque.  
 ※2 : The structural limit value, while the actual operating speed will vary depending on the motor.  
 ※3 : For this series of rotary tables, if sudden power outages may occur in the operating environment, motors equipped with a brake function are recommended to prevent displacement or slipping of the rotary or tilting axis during power loss, which could lead to collisions or other accidents.

### RC-255N

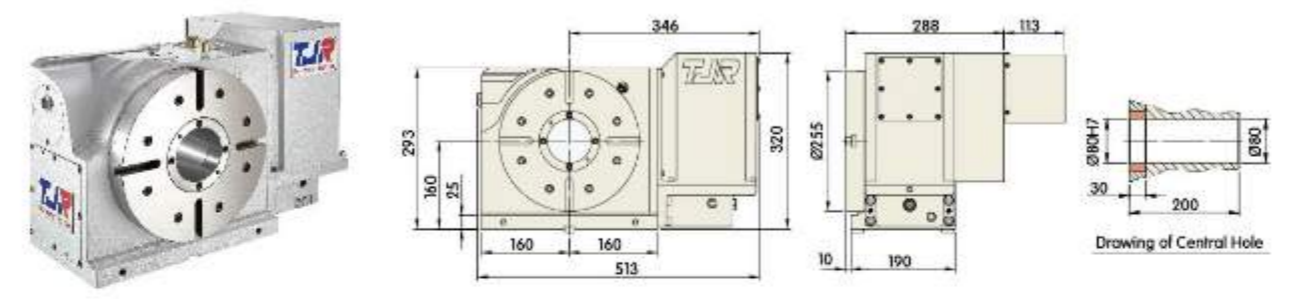

### RC-320N

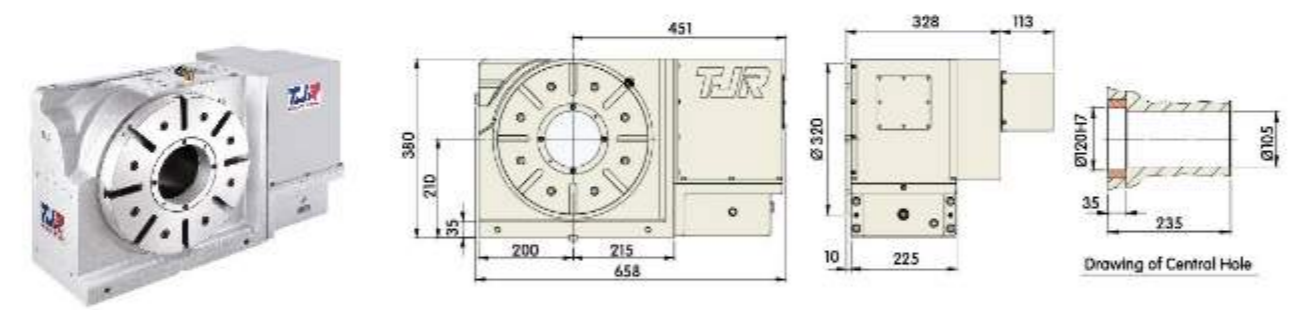

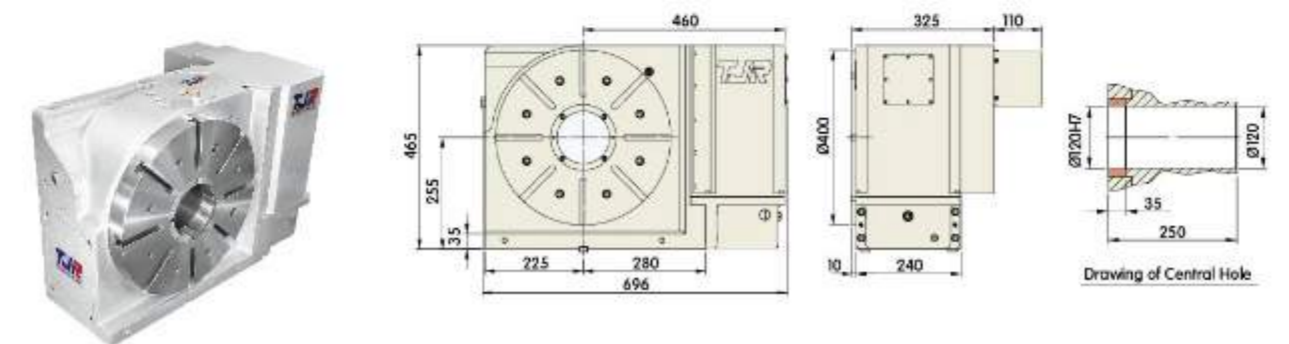

### RC-400N



## RC Series (Pneumatic / Hydraulic Brake) Left-side motor

**RC - 170 H L**









 Vertical  
 Horizontal

**RC** Roller Gear Cam Drive (Min. Indexing Angle: 0.001°)  
**HRC** Swivel Head with Roller Gear Cam Drive (also applicable for horizontal setup) (Min. Indexing Angle: 0.001°)

**L** Left-side Motor; Vertical & Horizontal use  
**SP** Swivel Spindle Head  
 Hydraulic Brake Option

Table Diameter  
 Use radial & axial bearings  
 Wrap-around Brake



Item / Model	Unit	RC-170(H)L		RC-210(H)L / RC-250(H)L		RC-320L	HRC-400SP
Table Diameter	mm	Ø170		Ø210 / Ø250		Ø320	Spindle interface
Inner Diameter of Mandrel Sleeve	mm	Ø40H7		Ø40H7		Ø120H7 x 35 deep	-
Diameter of Center Through Hole	mm	Ø40		Ø40		Ø105	Ø34 (Ø60)
Center Height (Vertical)	mm	135		160		210	-
Table Height (Horizontal)	mm	152		152 / 185		235	265
Table T-slot Width	mm	12H7		12H7		14H7	-
Guide Block Width	mm	18h7		18h7		18h7	-
Min. Increment	deg.	0.001		0.001		0.001	0.001
Indexing Precision (A axis 0°~+90°)	sec.	30		30		20	20
Repeatability	sec.	6		6		6	6
Clamping System : Pne. 0.6(6) / Hyd. 3.5(35)	MPa (kgf/cm <sup>2</sup> )	Pne.	Hyd.	Pne.	Hyd.	Hyd.	Hyd. 4.5(45)
Clamping torque (※1)	N·m (kgf·m)	304 (31)	491 (50)	304 (31)	491 (50)	1128 (115)	200
Servo Motor Type (※3)	FANUC	Straight shaft without key		αiF8 / βis8		αiF12 / βis22	αiF12 / βis22
	MITSUBISHI	Straight shaft without key		HG - 54 / 104		HG - 204	HG / HF - 204
	SIEMENS	Straight shaft		1FK7060 / 7063		1FK7083	1FK7083
Speed Reduction Ratio	-	1 / 36		1 / 36		1 / 90	1 / 90
Max. Rotation Rate of Table (※2)	min <sup>-1</sup>	83.3		83.3		33.3	33.3
Allowable Inertia Load Capacity (Vertical)	kg·m <sup>2</sup>	0.63		0.63		3.15	-
Allowable Workpiece Load	Vertical 	kg	75	75	150	-	-
	with support table	kg	150	150	350	-	-
	Horizontal 	kg	150	150	350	-	-
	0° Horizontal 	kg	-	-	-	-	-
	0°-90° Tilt 	kg	-	-	-	-	Vertical  200
Allowable Thrust Load (with Rotary Table Clamping)	F 	N (kgf)	14225 (1450)	14225 (1450)	29430 (3000)	-	-
	FxL 	N·m (kgf·m)	1079 (110)	1079 (110)	2943 (300)	3924 (400)	-
	FxL 	N·m (kgf·m)	304 (31)	304 (31)	1128 (115)	1128 (115)	-
Driving Torque	N·m (kgf·m)	363 (37)		363 (37)		1050 (107)	143 (dynamic) (1400)
Net Weight (without motor)	kg	44		52 / 62		187	406

※1 : If a mechanical brake is not used, this value will correspond to the motor's holding torque.  
 ※2 : The structural limit value, while the actual operating speed will vary depending on the motor.  
 ※3 : For this series of rotary tables, if sudden power outages may occur in the operating environment, motors equipped with a brake function are recommended to prevent displacement or slipping of the rotary or tilting axis during power loss, which could lead to collisions or other accidents.

### RC-170(H)L

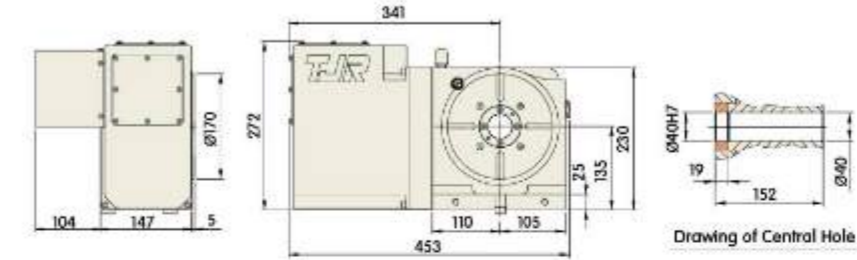

### RC-210(H)L / RC-250(H)L [Left-side Motor]

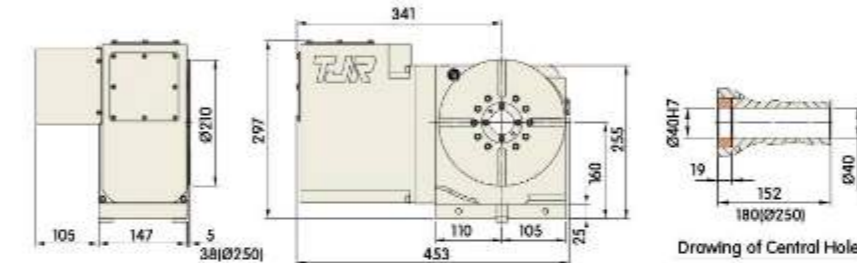

### RC-320L [Left-side Motor]

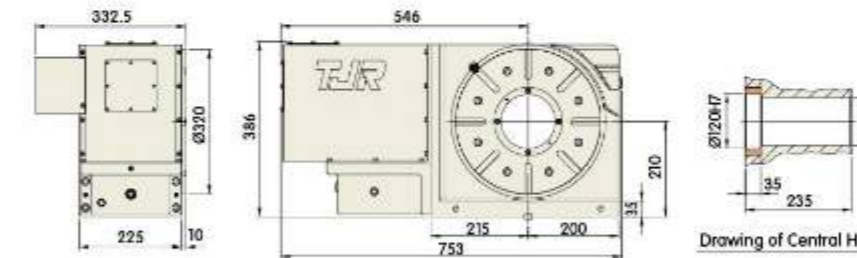

### HRC-400SP [Swivel (Spindle) Head]



(without spindle motor)

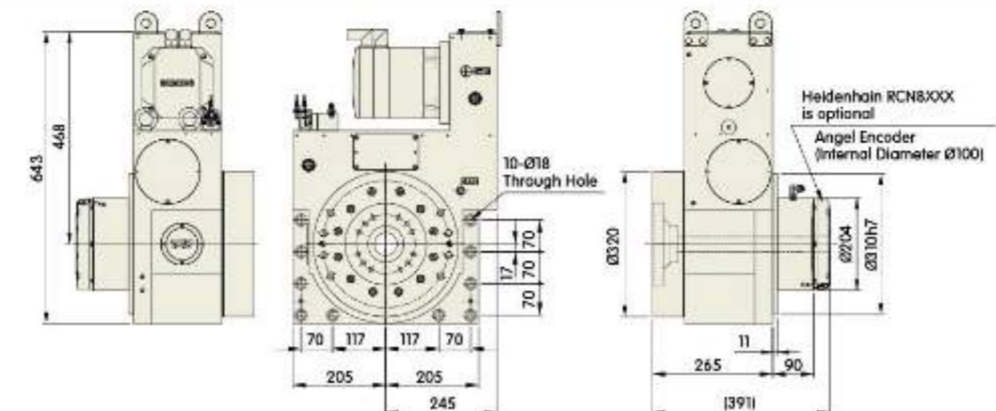

Driven by Roller Gear Cam

## FRC Series (Pneumatic / Hydraulic Brake)

### FRC - 255 C L - RC320

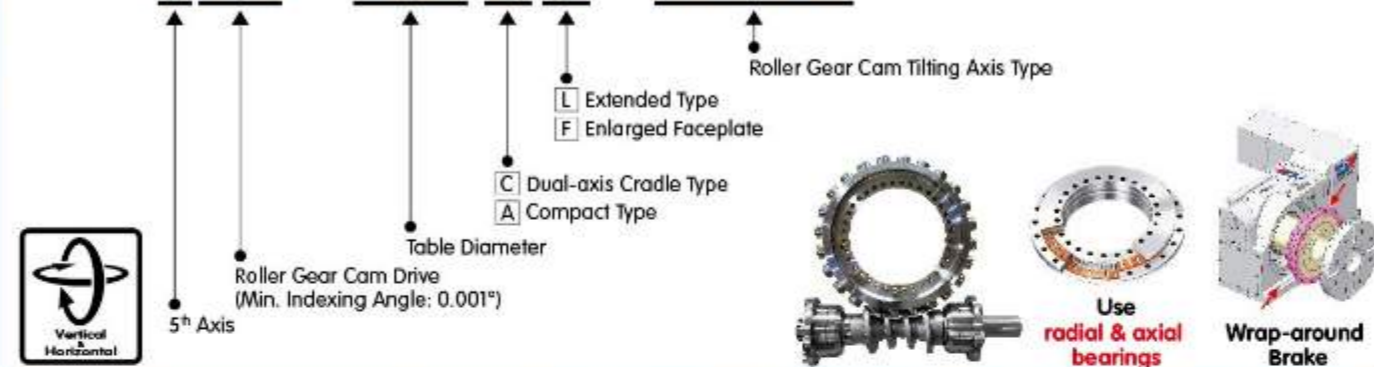

Item / Model	Unit	FRC-170A-RC210		FRC-210L-RC255		FRC-255CL-RC320		FRC-320CF-RC320			
Table Diameter	mm	Ø170		Ø210		Ø255		Ø320			
Inner Diameter of Mandrel Sleeve	mm	Ø40H7		Ø40H7		Ø80H7		Ø80H7			
Diameter of Center Through Hole	mm	Ø40		Ø35		Ø80		Ø80			
Table Height (Horizontal)	mm	245		270		310		310			
Table T-slot Width	mm	12H7		12H7		12H7		14H7			
Guide Block Width	mm	18h7		18h7		18h7		18h7			
Min. Increment	deg.	0.001		0.001		0.001		0.001			
Axis	-	Rotation	Tilt ±10°	Rotation	Tilt ±10°	Rotation	Tilt ±10°	Rotation	Tilt ±10°		
Indexing Precision	sec.	45	60	30	50	20	60	20	60		
Repeatability	sec.	6	8	6	8	6	8	6	8		
Clamping System : Pne. 0.6(6) / Hyd. 3.5(35)	MPa (kgf/cm <sup>2</sup> )	Hyd.	Hyd.	Pne. 0.5(5) (※4)	Pne. 0.5(5) (※4)	Hyd.	Hyd.	Hyd.	Hyd.		
Clamping torque (※1)	N·m (kgf·m)	245 (25)	491 (50)	294 (30)	1128 (115)	687 (70)	1717 (175)	687 (70)	1717 (175)		
Servo Motor Type (※2)(※5)	FANUC	Straight shaft without key	aIS4 / βis4	aIF4 / βisβ	aIF8 / βisβ	aIF8 / βisβ	aIF8 / βisβ	aIF8 / βis12	aIS12 / aIF12 / βis12	aIF8 / βis12	aIS12 / aIF12 / βis12
	MITSUBISHI	Straight shaft without key	HG-105	HG-54/104	HG-104	HG-154	HG-154	HG-204	HG-154	HG-204	HG-204
Speed Reduction Ratio	-	1 / 60	1 / 36	1 / 60	1 / 90	1 / 60	1 / 120	1 / 60	1 / 120	1 / 120	
Max. Rotation Rate of Table (※3)	min <sup>-1</sup>	50	50	50	25	50	25	50	25	25	
Allowable Inertia Load Capacity (Horizontal)	kg·m <sup>2</sup>	0.33		0.59		2.56		2.56			
Allowable Workpiece Load	0° Horizontal	kg		kg		kg		kg			
	0°-90° Tilt	kg		kg		kg		kg			
Allowable Thrust Load (with Rotary Table Clamping)	F	N (kgf)		N (kgf)		N (kgf)		N (kgf)			
	FxL	N·m (kgf·m)		N·m (kgf·m)		N·m (kgf·m)		N·m (kgf·m)			
	FxL	N·m (kgf·m)		N·m (kgf·m)		N·m (kgf·m)		N·m (kgf·m)			
	FxL	N·m (kgf·m)		N·m (kgf·m)		N·m (kgf·m)		N·m (kgf·m)			
Driving Torque	N·m (kgf·m)	245 (25)		363 (37)		540 (55)		540 (55)			
Net Weight (without motor)	kg	140		315		580		580			

※1 : If a mechanical brake is not used, this value will correspond to the motor's holding torque.  
 ※2 : Standard configuration: straight shaft without key. Please inquire for tapered-shaft motor compatibility.  
 ※3 : The structural limit value, while the actual operating speed will vary depending on the motor.  
 ※4 : This model is equipped with a built-in air-to-oil booster cylinder and requires only 5 kg/cm<sup>2</sup> of inlet air pressure to operate.  
 ※5 : For this rotary table series, a brake motor is recommended where sudden power loss may occur to prevent rotary or tilting axis movement and possible collisions.

### FRC-170A-RC210

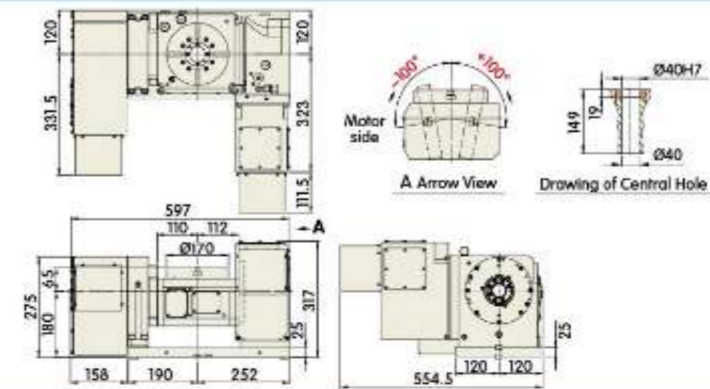

### FRC-210L-RC255 (Customizable Ø500 mm max. workpiece range for light-duty machining and large rotations.)



Compatible with 4-port rotary joint

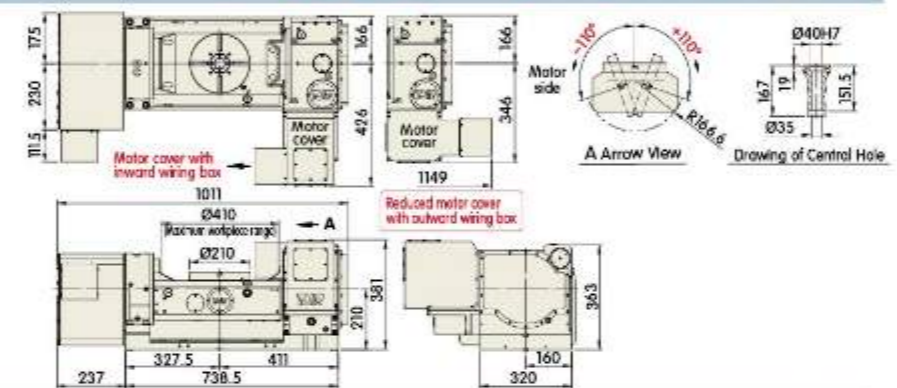

### FRC-255CL-RC320 (Customizable Ø600 mm max. workpiece range for light-duty machining and large rotations.)



Compatible with 6-port rotary joint and angle encoder

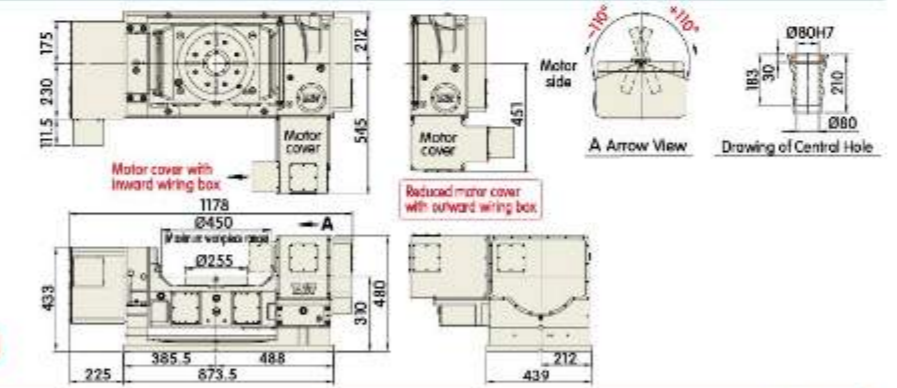

### FRC-320CF-RC320



Compatible with 6-port rotary joint and angle encoder

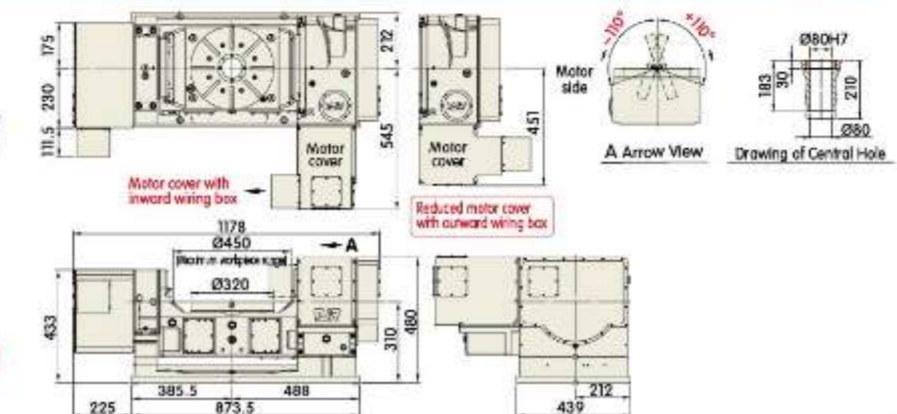

## FHR Series (Pneumatic / Hydraulic Brake)

### FHR - 350 C F - 2W - RC320 - 2A

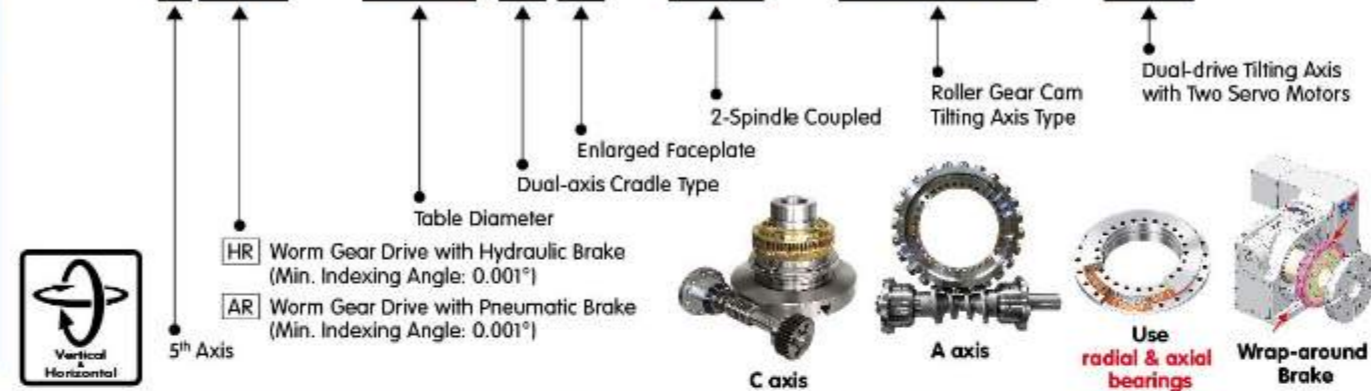

Item / Model	Unit	FAR-170-2W-RC255 / FAR-210-2W-RC255	FHR-255-2W-RC320	FHR-350F-2W-RC320-2A	FHR-350CF-2W-RC320-2A				
Table Diameter	mm	Ø170 / Ø210	Ø255	Ø350	Ø350				
Distance between Table Centers	mm	240	400	450	450				
Inner Diameter of Mandrel Sleeve	mm	Ø40H7	Ø80H7	Ø120H7	Ø120H7				
Diameter of Center Through Hole	mm	Ø40	Ø80	Ø120 x 200 deep	Ø120 x 200 deep				
Table Height (Horizontal)	mm	280	290	370	380				
Table T-slot Width	mm	12H7	12H7	14H7	14H7				
Guide Block Width	mm	18h7	18h7	18h7	18h7				
Min. Increment	deg.	0.001	0.001	0.001	0.001				
Axis	-	Rotation	Tilt ±110°	Rotation	Tilt ±110°	Rotation	Tilt ±110°	Rotation	Tilt ±110°
Indexing Precision	sec.	40	60	40	60	40	60	40	60
Repeatability	sec.	6	8	6	8	6	8	6	8
Clamping System : Pne. 0.6(6) / Hyd. 3.5(35)	MPa (kgf/cm <sup>2</sup> )	Pne.	Hyd.	Hyd.	Hyd.	Hyd.	Hyd.	Hyd.	Hyd.
Clamping torque (※1)	N·m (kgf·m)	304 (31)	1373 (140)	687 (70)	1717 (175)	1128 (115)	2256 (230)	1128 (115)	2256 (230)
Servo Motor Type (※3)	FANUC	Straight shaft without key	αiF8 / αiS12 / βis12	αiS12 / βis12	αiS12 / βis12	αiF12 / βis22	αiS12 x 2 / βis12 x 2	αiF12 / βis22	αiS12 x 2 / βis12 x 2
	MITSUBISHI	Straight shaft without key	HG-154	HG-154	HG-154	HG-204/354	HG-204	HG-154 x 2	HG-204
Speed Reduction Ratio	-	1 / 90	1 / 60	1 / 150	1 / 90	1 / 120	1 / 90	1 / 120	1 / 90
Max. Rotation Rate of Table (※2)	min <sup>-1</sup>	44.4	16.6	20	16.6	25	16.6	25	16.6
Allowable Inertia Load Capacity (Horizontal)	kg·m <sup>2</sup>	0.3	0.8	2.3	2.3				
Allowable Workpiece Load	0° Horizontal	kg	50 (One pallet)	100 (One pallet)	150 (One pallet)	150 (One pallet)			
	0°-90° Tilt	kg	40 (One pallet)	75 (One pallet)	150 (One pallet)	150 (One pallet)			
Allowable Thrust Load (With Rotary Table Clamping)	F	N (kgf)	7358 (750)	14715 (1500)	17658 (1800)	17658 (1800)			
	FxL	N·m (kgf·m)	1373 (140)	1717 (175)	2256 (230)	2256 (230)			
	FxL	N·m (kgf·m)	304 (31)	687 (70)	1128 (115)	1128 (115)			
Driving Torque	N·m (kgf·m)	177 (18)	540 (55)	785 (80)	785 (80)				
Net Weight (without motor)	kg	305(Ø170) / 312(Ø210)	740	1080	-				

※1 : If a mechanical brake is not used, this value will correspond to the motor's holding torque.  
 ※2 : The structural limit value, while the actual operating speed will vary depending on the motor.  
 ※3 : For this rotary table series, a brake motor is recommended where sudden power loss may occur to prevent rotary or tilting axis movement and possible collisions.

### FAR-170-2W-RC255 / FAR-210-2W-RC255



Compatible with 2-oil & 2-air port rotary joint

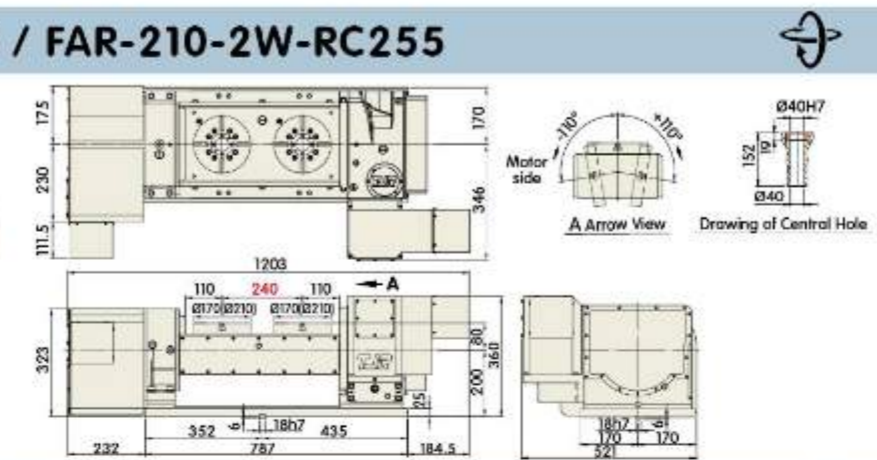

### FHR-255-2W-RC320



Compatible with 2-oil & 2-air port rotary joint

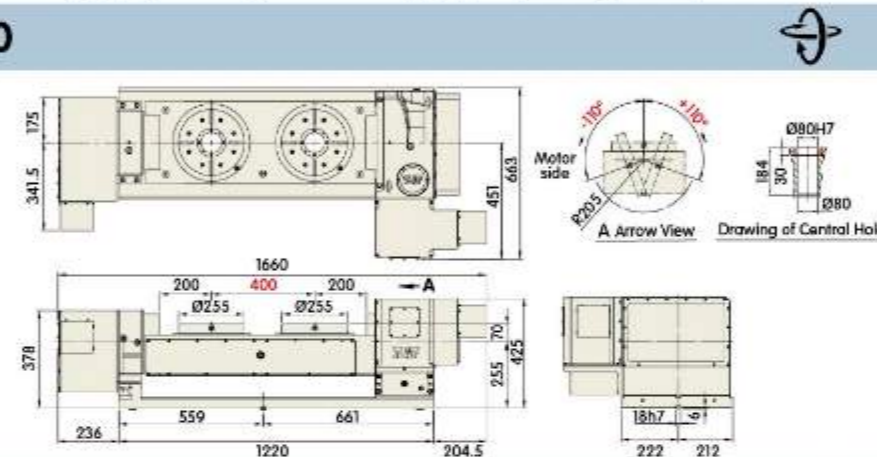

### FHR-350F-2W-RC320-2A



Compatible with 4-oil & 2-air port rotary joint

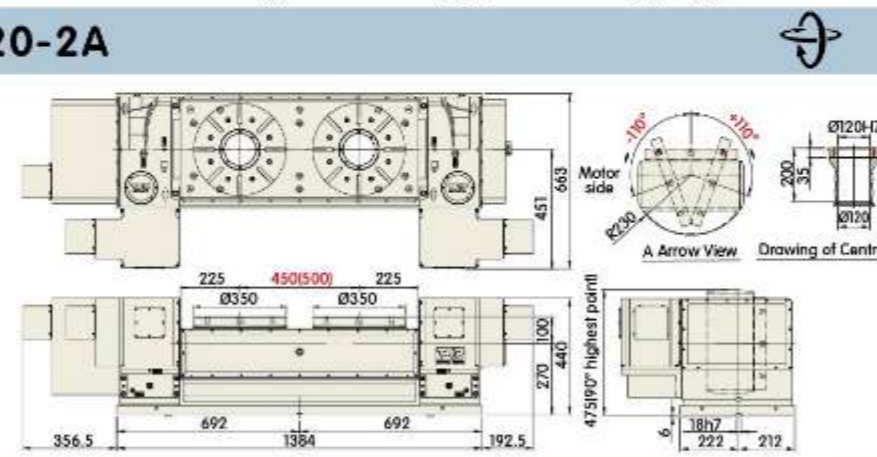

### FHR-350CF-2W-RC320-2A

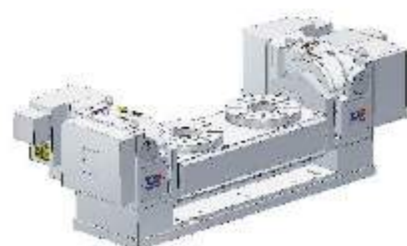

Compatible with 4-oil & 2-air port rotary joint

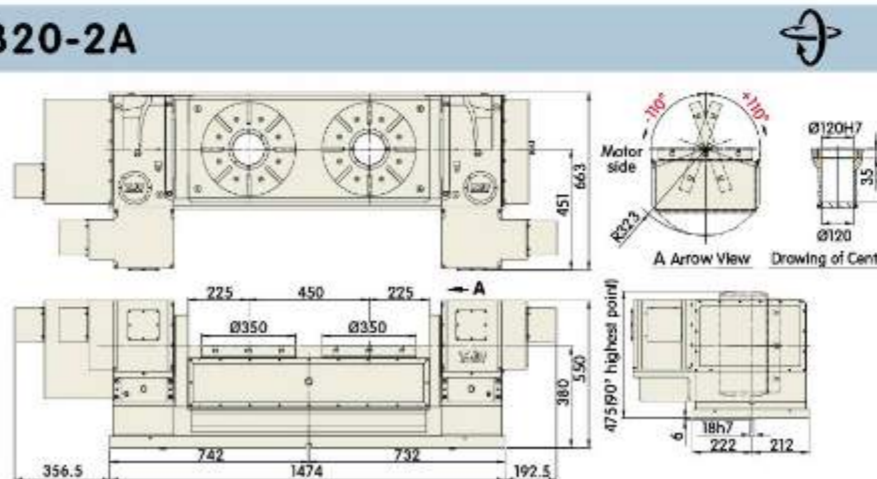

Driven by Roller Gear Cam

Driven by Roller Gear Cam

## AR Series (Pneumatic Brake)

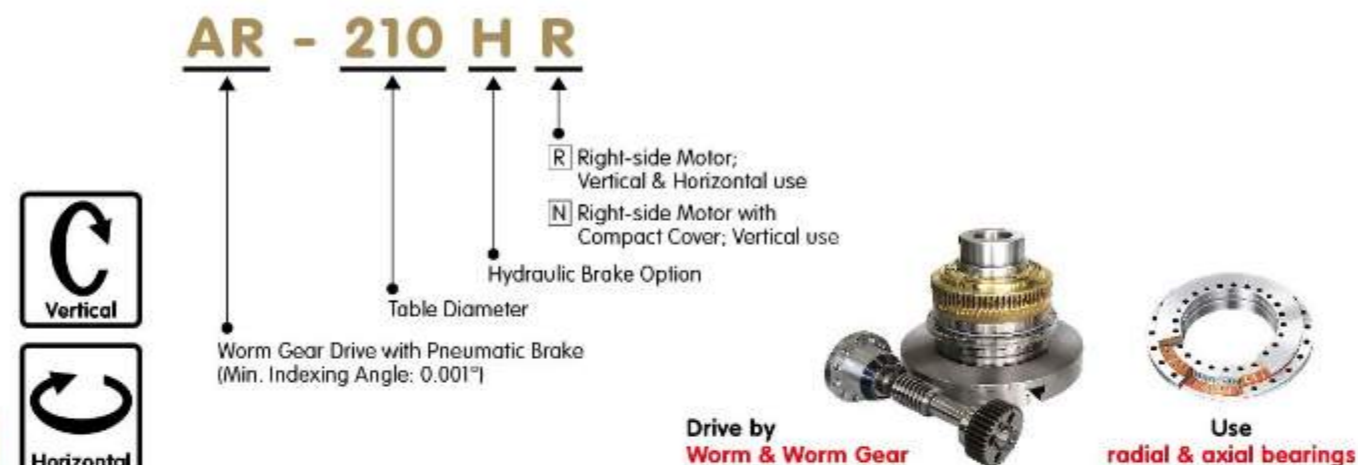

Item / Model	Unit	ARs-125R	AR-170(H)R	AR-210(H)R AR-250(H)R	AR-255HR	AR-255HN
Table Diameter	mm	Ø125	Ø170	Ø210 / Ø250	Ø255	Ø255
Inner Diameter of Mandrel Sleeve	mm	Ø35H7	Ø40H7	Ø40H7	Ø80H7	Ø80H7
Diameter of Center Through Hole	mm	Ø25	Ø40	Ø40	Ø80	Ø80
Center Height (Vertical)	mm	110	135	160	160	160
Table Height (Horizontal)	mm	152	152	152 / 160	200	-
Table T-slot Width	mm	12H7	12H7	12H7	12H7	12H7
Guide Block Width	mm	14h7	18h7	18h7	18h7	18h7
Min. Increment	deg.	0.001	0.001	0.001	0.001	0.001
Indexing Precision	sec.	40	20	20	15	15
Repeatability	sec.	6	6	6	6	6
Clamping System : Pne. 0.6[6] / Hyd. 3.5[35]	MPa (kgf/cm <sup>2</sup> )	Pne.	Pne. Hyd.	Pne. Hyd.	Pne.	Pne.
Clamping torque [※1]	N·m (kgf·m)	128 (13)	304 (31) 540 (55)	304 (31) 540 (55)	687 (70)	687 (70)
Servo Motor Type	FANUC	αiS4 / Bis4	αiF4 / Bis8	αiF8 / Bis8	αiF8 / Bis12	αiF8 / Bis12
	MITSUBISHI	HG - 75 / 105	HG - 54 / 104	HG - 54 / 104	HG - 154	HG - 154
Speed Reduction Ratio	-	1 / 60	1 / 90	1 / 90	1 / 120	1 / 120
Max. Rotation Rate of Table [※2]	min <sup>-1</sup>	33.3	44.4	44.4	33.3	33.3
Allowable Inertia Load Capacity (Vertical)	kg·m <sup>2</sup>	0.28	0.63	0.63	1.2	1.2
Allowable Workpiece Load	Vertical	kg	50	75	75	100
	with support table	kg	100	150	150	250
	Horizontal	kg	100	150	150	250
Allowable Thrust Load (with Rotary Table Clamping)	F	N (kgf)	9810 (1000)	14225 (1450)	14225 (1450)	19620 (2000)
	FxL	N·m (kgf·m)	441 (45)	1079 (110)	1079 (110)	1472 (150)
	FyL	N·m (kgf·m)	128 (13)	304 (31)	304 (31)	687 (70)
	FzL	N·m (kgf·m)	128 (13)	304 (31)	304 (31)	687 (70)
Driving Torque	N·m (kgf·m)	88 (9)	284 (29)	284 (29)	540 (55)	540 (55)
Net Weight (without motor)	kg	34	50	55 / 58	118	118

※1 : If a mechanical brake is not used, this value will correspond to the motor's holding torque.  
 ※2 : The structural limit value, while the actual operating speed will vary depending on the motor.

### ARs-125R



### AR-170(H)R

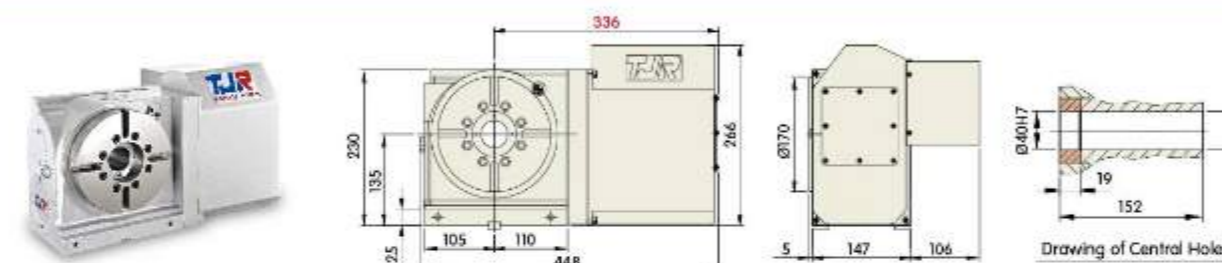

### AR-210(H)R / AR-250(H)R

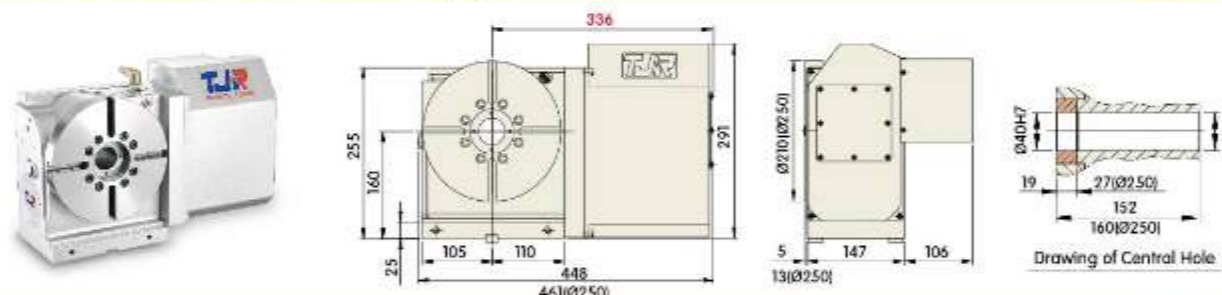

### AR-255HR

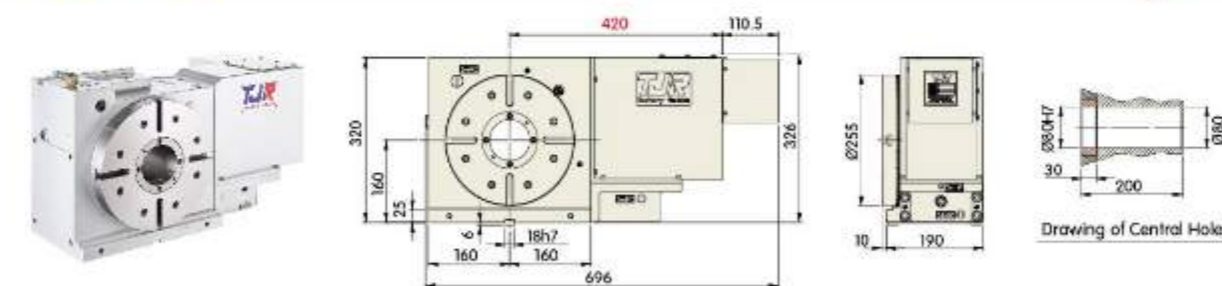

### AR-255HN

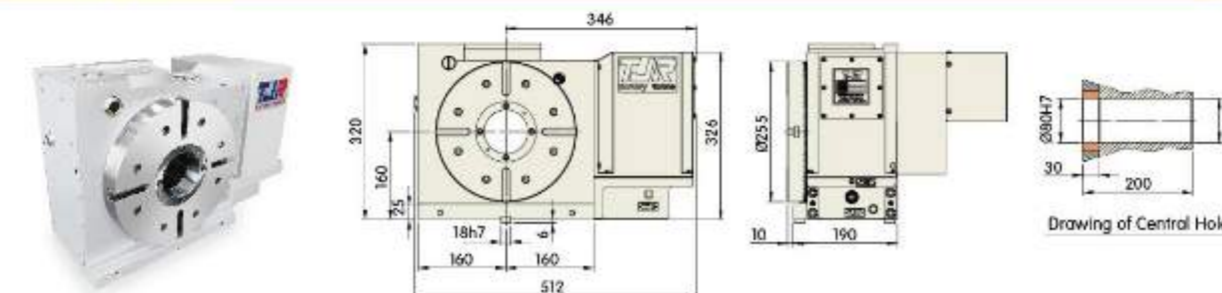

Driven by Worm & Worm Gear

## AR Series (Pneumatic Brake) Left-side motor



Item / Model	Unit	ARs-125L	AR-170(H)L	AR-210(H)L	AR-250(H)L
Table Diameter	mm	Ø125	Ø170	Ø210	Ø250
Inner Diameter of Mandrel Sleeve	mm	Ø35H7	Ø40H7	Ø40H7	Ø40H7
Diameter of Center Through Hole	mm	Ø25	Ø40	Ø40	Ø40
Center Height (Vertical)	mm	110	135	160	160
Table Height (Horizontal)	mm	152	152	152	160
Table T-slot Width	mm	12H7	12H7	12H7	12H7
Guide Block Width	mm	14h7	18h7	18h7	18h7
Min. Increment	deg.	0.001	0.001	0.001	0.001
Indexing Precision	sec.	40	20	20	20
Repeatability	sec.	6	6	6	6
Clamping System : Pne. 0.6[6] / Hyd. 3.5[35]	MPa (kgf/cm <sup>2</sup> )	Pne.	Pne. Hyd.	Pne. Hyd.	Pne. Hyd.
Clamping torque [※1]	N·m (kgf·m)	128 (13)	304 (31) 540 (55)	304 (31) 540 (55)	304 (31) 540 (55)
Servo Motor Type	FANUC	αiS4 / Bis4	αiF4 / Bis8	αiF8 / Bis8	αiF8 / Bis8
	MITSUBISHI	HG - 75 / 105	HG - 54 / 104	HG - 54 / 104	HG - 54 / 104
Speed Reduction Ratio	-	1 / 60	1 / 90	1 / 90	1 / 90
Max. Rotation Rate of Table [※2]	min <sup>-1</sup>	33.3	44.4	44.4	44.4
Allowable Inertia Load Capacity (Vertical)	kg·m <sup>2</sup>	0.28	0.63	0.63	0.63
Allowable Workpiece Load	Vertical	kg	50	75	75
	with support table	kg	100	150	150
	Horizontal	kg	100	150	150
Allowable Thrust Load (with Rotary Table Clamping)	F	N (kgf)	9810 (1000)	14225 (1450)	14225 (1450)
	FxL	N·m (kgf·m)	441 (45)	1079 (110)	1079 (110)
	FxL	N·m (kgf·m)	128 (13)	304 (31)	304 (31)
	Driving Torque	N·m (kgf·m)	88 (9)	284 (29)	284 (29)
Net Weight (without motor)	kg	34	50	55	58

※1 : If a mechanical brake is not used, this value will correspond to the motor's holding torque.  
 ※2 : The structural limit value, while the actual operating speed will vary depending on the motor.

### ARs-125L

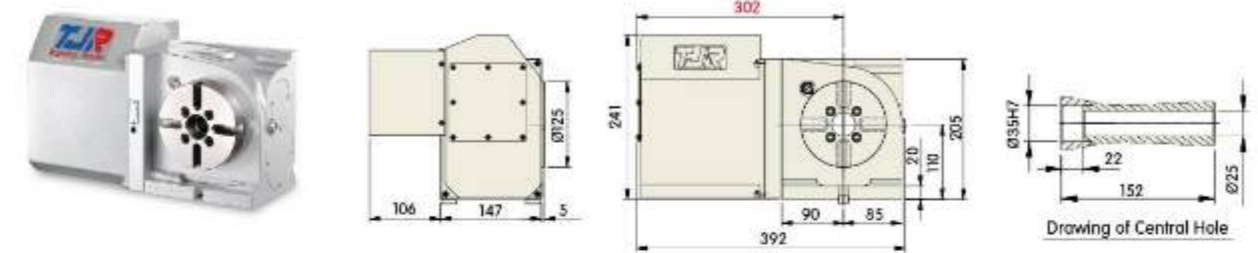

### AR-170(H)L

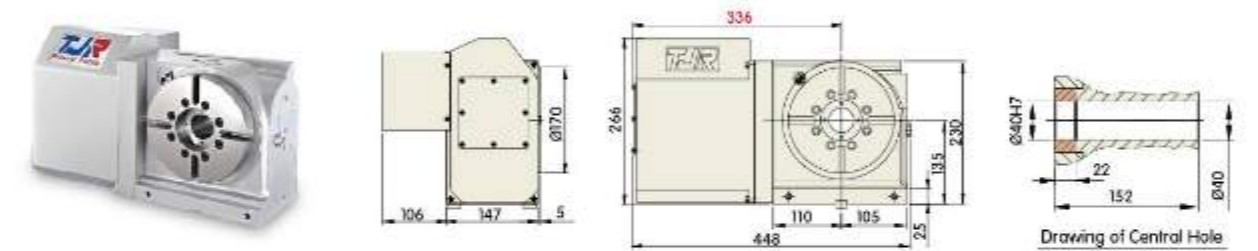

### AR-210(H)L

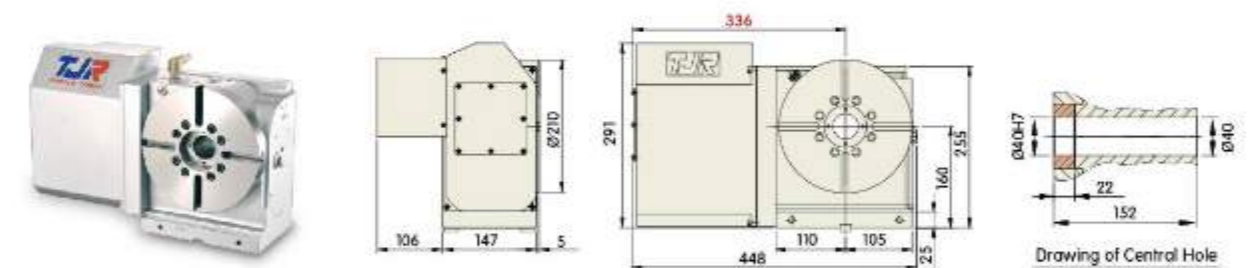

### AR-250(H)L

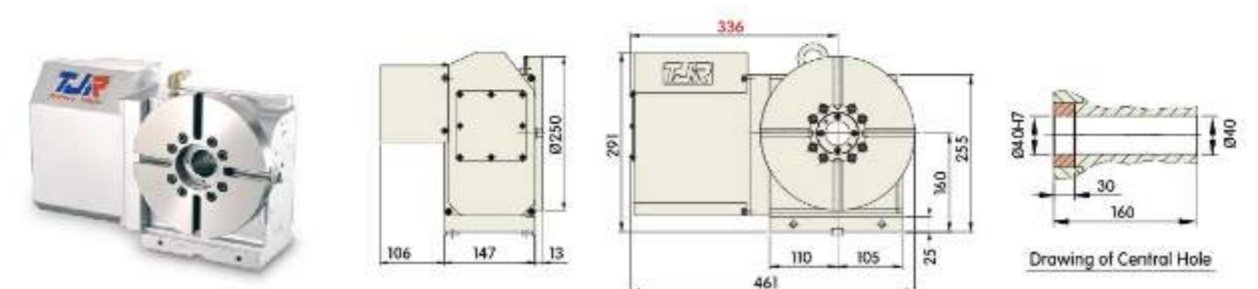

Driven by Worm & Worm Gear

## AR Series (Pneumatic Brake) Back-side motor

### AR - 210 H B

Worm Gear Drive with Pneumatic Brake  
(Min. Indexing Angle: 0.001°)

Table Diameter

Hydraulic Brake Option

Back-side Motor; Vertical use



Drive by **Worm & Worm Gear** Use **radial & axial bearings**



Item / Model	Unit	ARs-125B	AR-170(H)B	AR-210(H)B	AR-250(H)B	
Table Diameter	mm	Ø125	Ø170	Ø210	Ø250	
Inner Diameter of Mandrel Sleeve	mm	Ø35H7	Ø40H7	Ø40H7	Ø40H7	
Diameter of Center Through Hole	mm	Ø25x152 deep	Ø40x152 deep	Ø40x152 deep	Ø40x152 deep	
Center Height (Vertical)	mm	110	135	160	160	
Table Height (Horizontal)	mm	-	-	-	-	
Table T-slot Width	mm	12H7	12H7	12H7	12H7	
Guide Block Width	mm	14h7	18h7	18h7	18h7	
Min. Increment	deg.	0.001	0.001	0.001	0.001	
Indexing Precision	sec.	40	20	20	20	
Repeatability	sec.	6	6	6	6	
Clamping System : Pne. 0.6[6] / Hyd. 3.5[35]	MPa (kgf/cm <sup>2</sup> )	Pne.	Pne. Hyd.	Pne. Hyd.	Pne. Hyd.	
Clamping torque [※1]	N·m (kgf·m)	128 (13)	304 (31) 540 (55)	304 (31) 540 (55)	304 (31) 540 (55)	
Servo Motor Type	FANUC	Straight shaft without key	αiS4 / Bis4	αiF4 / αiF8 / Bis8	αiF8 / Bis8	αiF8 / Bis8
	MITSUBISHI	Straight shaft without key	HG - 75 / 105	HG - 54 / 104	HG - 54 / 104	HG - 54 / 104
Speed Reduction Ratio	-	1 / 60	1 / 90	1 / 90	1 / 90	
Max. Rotation Rate of Table [※2]	min <sup>-1</sup>	33.3	44.4	44.4	44.4	
Allowable Inertia Load Capacity (Vertical)	kg·m <sup>2</sup>	0.28	0.63	0.63	0.63	
Allowable Workpiece Load	Vertical	kg	50	75	75	75
	with support table	kg	100	150	150	150
	Horizontal	kg	-	-	-	-
Allowable Thrust Load (with Rotary Table Clamping)	F	N (kgf)	9810 (1000)	14225 (1450)	14225 (1450)	14225 (1450)
	FxL	N·m (kgf·m)	441 (45)	1079 (110)	1079 (110)	1079 (110)
	FxL	N·m (kgf·m)	128 (13)	304 (31)	304 (31)	304 (31)
	FxL	N·m (kgf·m)	88 (9)	284 (29)	284 (29)	284 (29)
Driving Torque	N·m (kgf·m)	88 (9)	284 (29)	284 (29)	284 (29)	
Net Weight (without motor)	kg	44	60	65	72	

※1 : If a mechanical brake is not used, this value will correspond to the motor's holding torque.  
 ※2 : The structural limit value, while the actual operating speed will vary depending on the motor.

### ARs-125B

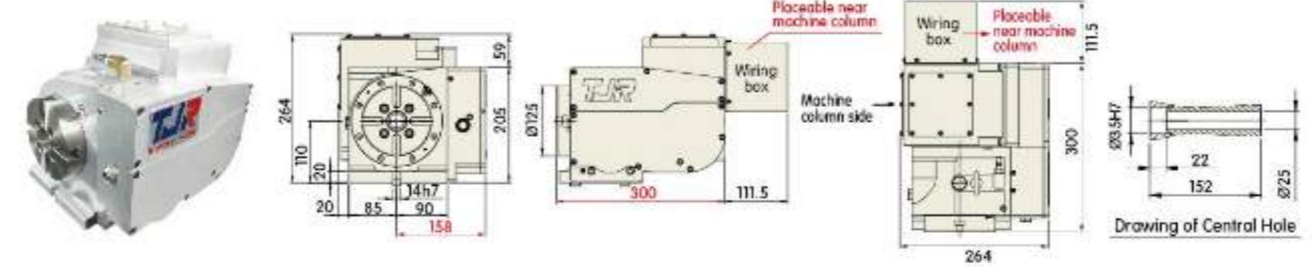

### AR-170(H)B

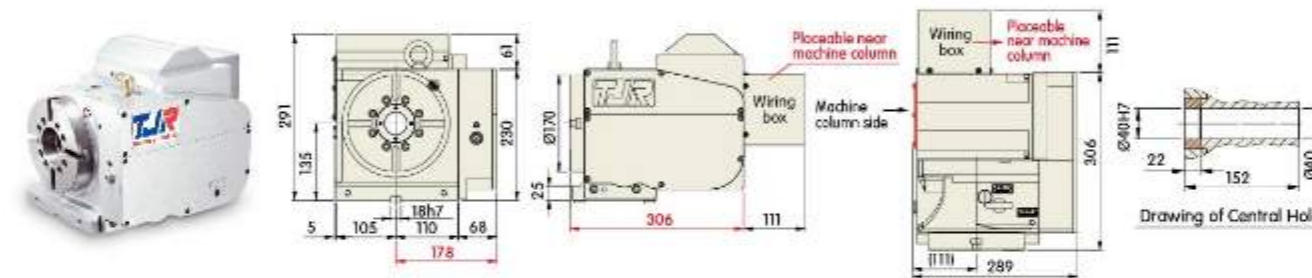

### AR-210(H)B

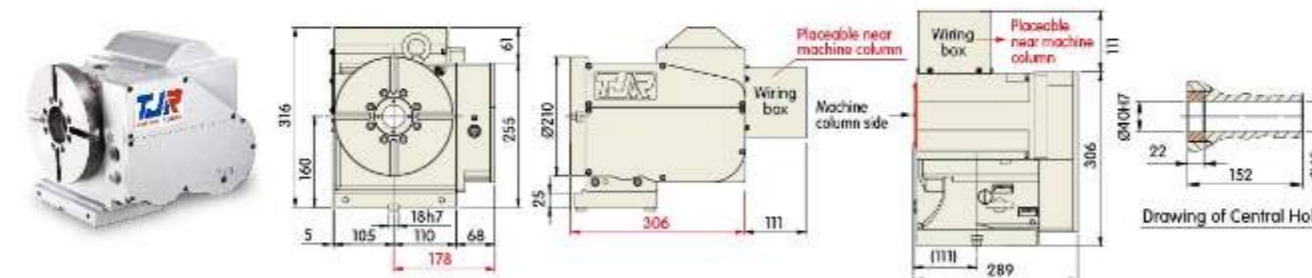

### AR-250(H)B

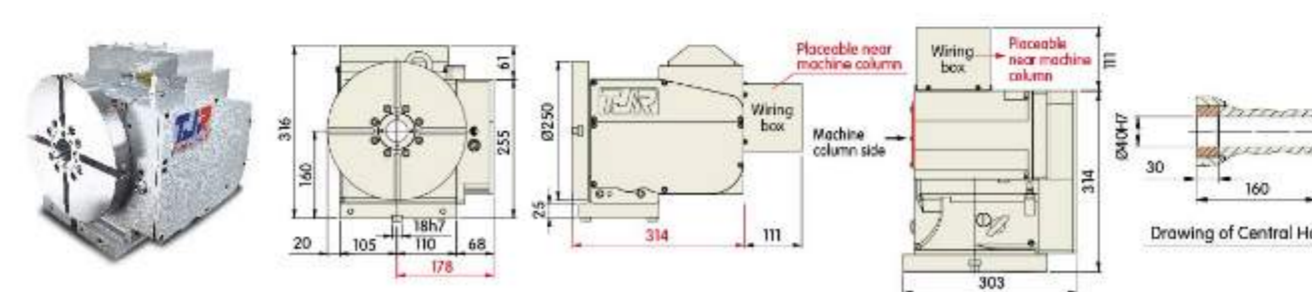

Driven by **Worm & Worm Gear**

Driven by **Worm & Worm Gear**

## AR Multi-Spindle Series (Pneumatic Brake)

### AR - 125 - 2W

2W 2-Spindle Coupled  
3W 3-Spindle Coupled  
4W 4-Spindle Coupled





Table Diameter

Worm Gear Drive with Pneumatic Brake  
(Min. Indexing Angle: 0.001°)



Drive by **Worm & Worm Gear**  
Use **radial & axial bearings**



Item / Model	Unit	ARs-125-2W	ARs-125-3W	ARs-125-4W	
Table Diameter	mm	Ø125	Ø125	Ø125	
Inner Diameter of Mandrel Sleeve	mm	Ø35H7	Ø35H7	Ø35H7	
Diameter of Center Through Hole	mm	Ø25	Ø25	Ø25	
Center Height (Vertical)	mm	135	135	135	
Distance between Table Centers	mm	200	200	200	
Table T-slot Width	mm	12H7	12H7	12H7	
Guide Block Width	mm	14h7	14h7	14h7	
Min. Increment	deg.	0.001	0.001	0.001	
Indexing Precision	sec.	60	60	90	
Repeatability	sec.	6	6	6	
Clamping System : Pneumatic	MPa (kgf/cm <sup>2</sup> )	0.6 (6)	0.6 (6)	0.6 (6)	
Clamping torque ※1	N·m (kgf·m)	128 (13)	128 (13)	128 (13)	
Servo Motor Type	FANUC	Straight shaft without key αiF4 / βis8	αiF8 / βis8	αiF8 / βis12	
	MITSUBISHI	Straight shaft without key HG - 104	HG - 154	HG - 224	
Speed Reduction Ratio	-	1 / 60	1 / 60	1 / 60	
Max. Rotation Rate of Table ※2	min <sup>-1</sup>	33.3	33.3	33.3	
Allowable Inertia Load Capacity (Vertical)	kg·m <sup>2</sup>	0.28	0.28	0.28	
Allowable Workpiece Load	Vertical 	kg	50	50	50
	with support table	kg	100	100	100
	Horizontal 	kg	-	-	-
Allowable Thrust Load (with Rotary Table Clamping)	F 	N (kgf)	9810 (1000)	9810 (1000)	9810 (1000)
	FxL 	N·m (kgf·m)	441 (45)	441 (45)	441 (45)
	FxL 	N·m (kgf·m)	128 (13)	128 (13)	128 (13)
Driving Torque	N·m (kgf·m)	88 (9)	88 (9)	88 (9)	
Net Weight (without motor)	kg	82	120	-	

※1 : If a mechanical brake is not used, this value will correspond to the motor's holding torque.  
※2 : The structural limit value, while the actual operating speed will vary depending on the motor.

### ARs-125-2W

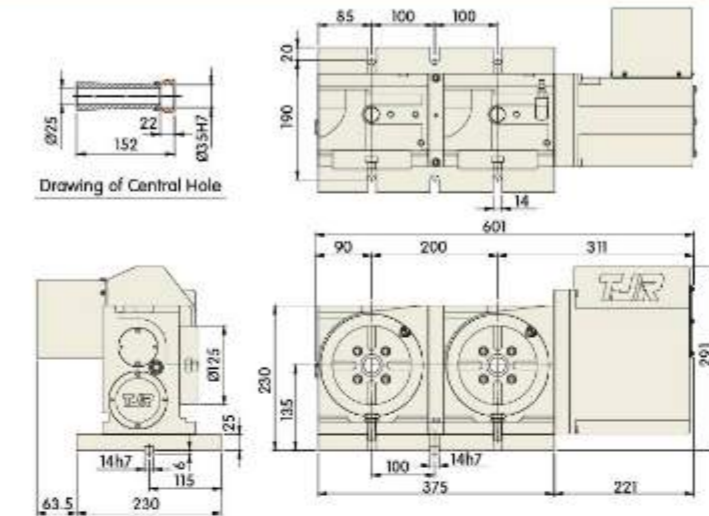

### ARs-125-3W

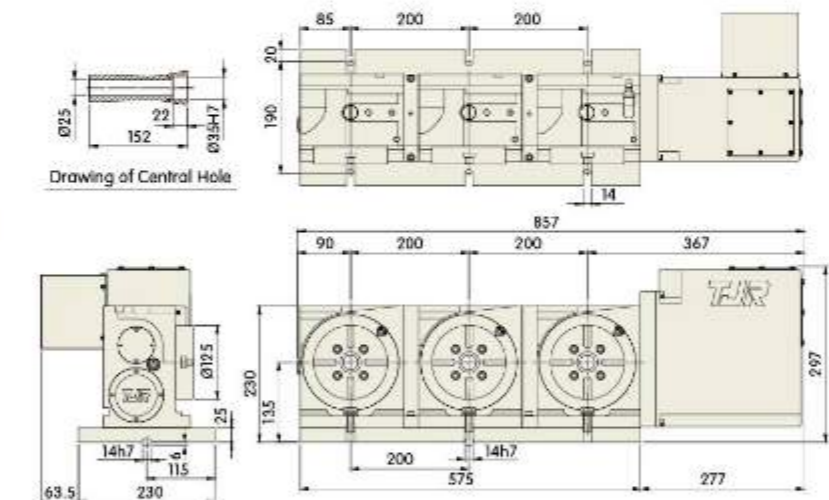

### ARs-125-4W

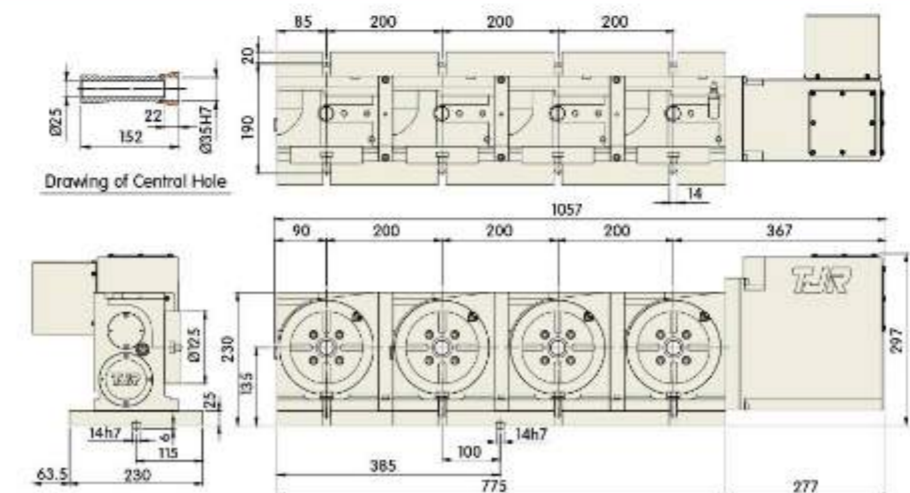

## AR Multi-Spindle Series (Pneumatic Brake)

### AR - 170 - 2W

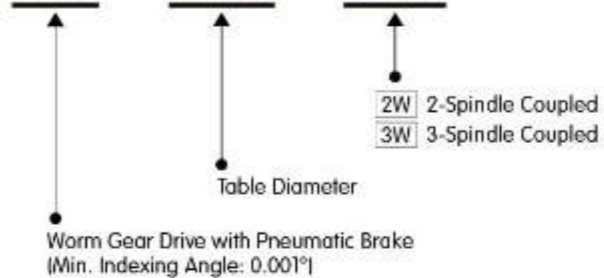

Drive by **Worm & Worm Gear** Use **radial & axial bearings**



Item / Model	Unit	AR-170-2W	AR-170-3W	AR-210-2W	AR-210-3W
Table Diameter	mm	Ø170	Ø170	Ø210	Ø210
Inner Diameter of Mandrel Sleeve	mm	Ø40H7	Ø40H7	Ø40H7	Ø40H7
Diameter of Center Through Hole	mm	Ø40	Ø40	Ø40	Ø40
Center Height (Vertical)	mm	175	175	200	200
Distance between Table Centers	mm	152	152	152	152
Table T-slot Width	mm	12H7	12H7	12H7	12H7
Guide Block Width	mm	18h7	18h7	18h7	18h7
Min. Increment	deg.	0.001	0.001	0.001	0.001
Indexing Precision	sec.	40	40	40	40
Repeatability	sec.	6	6	6	6
Clamping System : Pneumatic	MPa (kgf/cm <sup>2</sup> )	0.6 (6)	0.6 (6)	0.6 (6)	0.6 (6)
Clamping torque ※1	N·m (kgf·m)	304 (31)	304 (31)	304 (31)	304 (31)
Servo Motor Type	FANUC	Straight shaft without key	αiF8 / βis8	αiF8 / βis8	αiF8 / βis8
	MITSUBISHI	Straight shaft without key	HG - 104 / 154	HG - 104 / 154	HG - 104 / 154
Speed Reduction Ratio	-	1 / 90	1 / 90	1 / 90	1 / 90
Max. Rotation Rate of Table ※2	min <sup>-1</sup>	44.4	44.4	44.4	44.4
Allowable Inertia Load Capacity (Vertical)	kg·m <sup>2</sup>	0.63	0.63	0.63	0.63
Allowable Workpiece Load	Vertical	kg	75	75	75
	with support table	kg	150	150	150
	Horizontal	kg	-	-	-
Allowable Thrust Load (with Rotary Table Clamping)	F	N (kgf)	14225 (1450)	14225 (1450)	14225 (1450)
	FxL	N·m (kgf·m)	1079 (110)	1079 (110)	1079 (110)
	FxL	N·m (kgf·m)	304 (31)	304 (31)	304 (31)
	Driving Torque	N·m (kgf·m)	284 (29)	284 (29)	284 (29)
Net Weight (without motor)	kg	133	204	140	211

※1 : If a mechanical brake is not used, this value will correspond to the motor's holding torque.  
 ※2 : The structural limit value, while the actual operating speed will vary depending on the motor.

### AR-170-2W

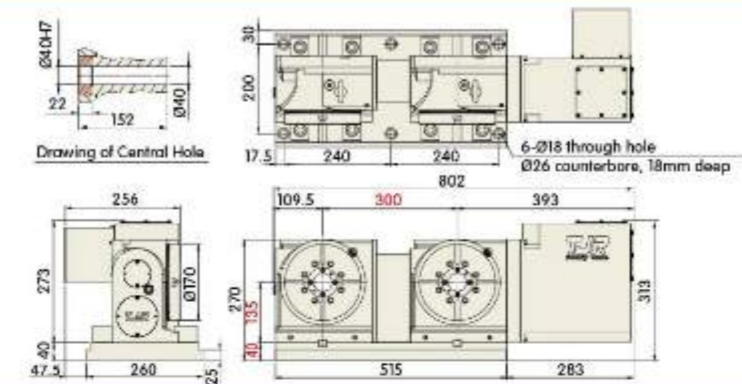

### AR-170-3W

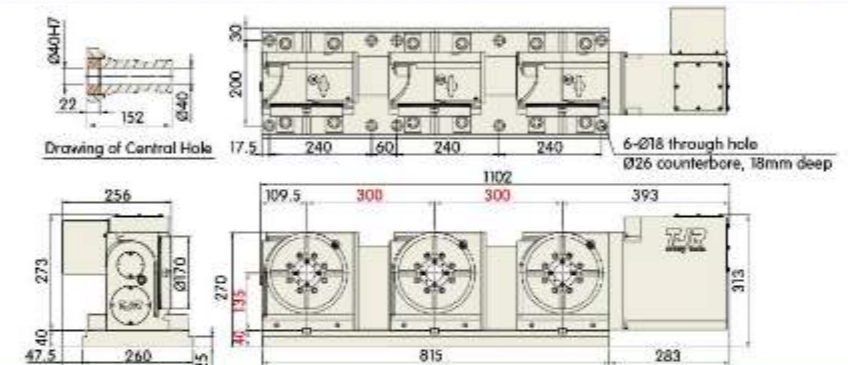

### AR-210-2W

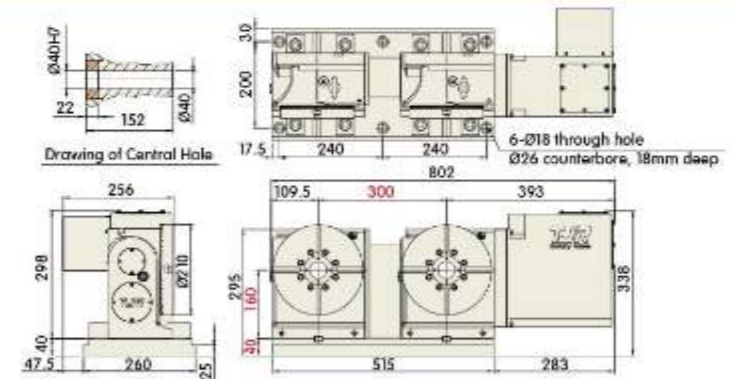

### AR-210-3W

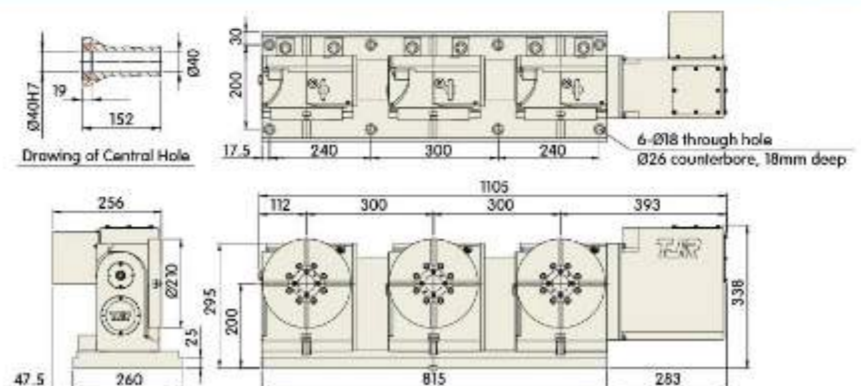

## HR Series (Hydraulic Brake)



Item / Model	Unit	HR-255R	HR-320R	HR-400R	
Table Diameter	mm	Ø255	Ø320	Ø400	
Inner Diameter of Mandrel Sleeve	mm	Ø80H7	Ø120H7	Ø120H7	
Diameter of Center Through Hole	mm	Ø80	Ø120	Ø120	
Center Height (Vertical)	mm	160	210	255	
Table Height (Horizontal)	mm	200	235	250	
Table T-slot Width	mm	12H7	14H7	14H7	
Guide Block Width	mm	18h7	18h7	18h7	
Min. Increment	deg.	0.001	0.001	0.001	
Indexing Precision	sec.	15	15	15	
Repeatability	sec.	6	6	6	
Clamping System : Hydraulic	MPa (kgf/cm <sup>2</sup> )	3.5 (35)	3.5 (35)	3.5 (35)	
Clamping torque ※1	N·m (kgf·m)	687 (70)	1128 (115)	1962 (200)	
Servo Motor Type	FANUC	Straight shaft without key	αiF8 / βis12	αiF12 / Bis22	αiF12 / Bis22
	MITSUBISHI	Straight shaft without key	HG - 154	HG - 204	HG - 204
Speed Reduction Ratio	-	1 / 120	1 / 120	1 / 120	
Max. Rotation Rate of Table ※2	min <sup>-1</sup>	33.3	25	25	
Allowable Inertia Load Capacity (Vertical)	kg·m <sup>2</sup>	1.2	3.1	6.2	
Allowable Workpiece Load	Vertical	kg	100	150	200
	with support table	kg	250	350	500
	Horizontal	kg	250	350	500
Allowable Thrust Load (with Rotary Table Clamping)	F	N (kgf)	19620 (2000)	29430 (3000)	39240 (4000)
	FxL	N·m (kgf·m)	1472 (150)	2943 (300)	3924 (400)
	FxL	N·m (kgf·m)	687 (70)	1128 (115)	1962 (200)
Driving Torque	N·m (kgf·m)	540 (55)	785 (80)	1668 (170)	
Net Weight (without motor)	kg	109	204	286	

※1 : If a mechanical brake is not used, this value will correspond to the motor's holding torque.  
 ※2 : The structural limit value, while the actual operating speed will vary depending on the motor.

### HR-255R

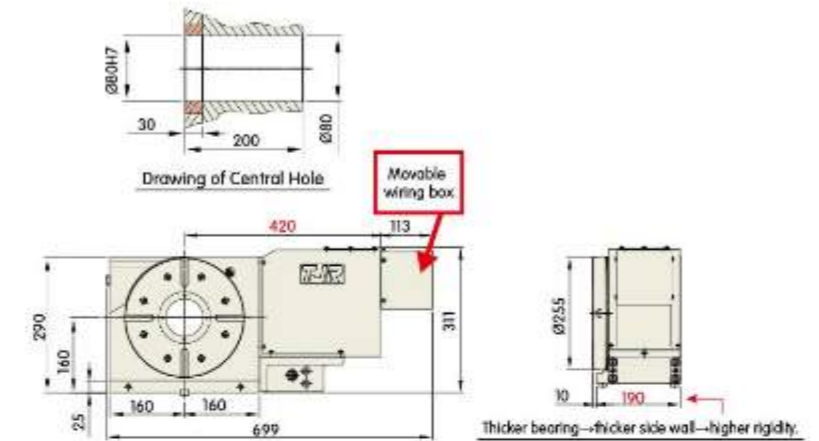

### HR-320R

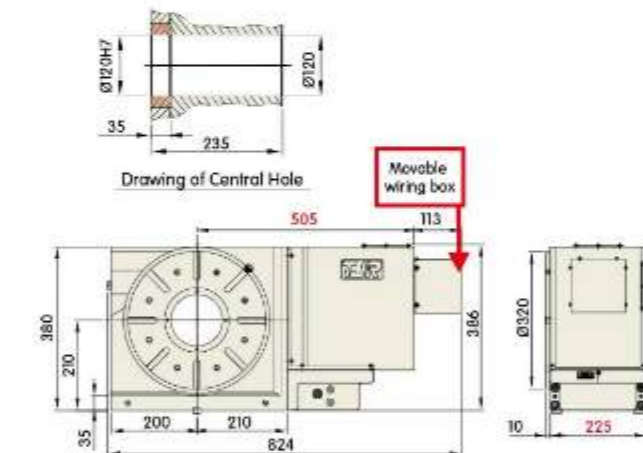

### HR-400R

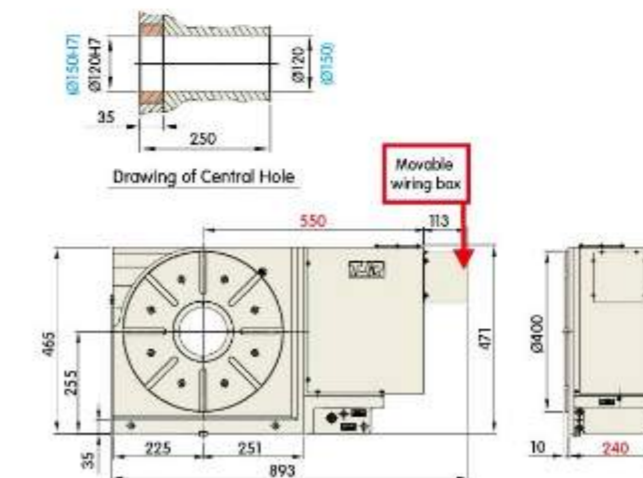

\*1) Ø150 central through hole is available.

## HR Series (Hydraulic Brake)

**HR - 255 N**

Worm Gear Drive with Hydraulic Brake  
(Min. Indexing Angle: 0.001°)

Table Diameter

Right-side Motor with Compact Cover; Vertical use



Drive by  
Worm & Worm Gear

Use  
radial & axial bearings

Wrap-around Brake



Item / Model	Unit	HR-255N	HR-320N	HR-400N
Table Diameter	mm	Ø255	Ø320	Ø400
Inner Diameter of Mandrel Sleeve	mm	Ø80H7	Ø120H7	Ø120H7
Diameter of Center Through Hole	mm	Ø80	Ø120	Ø120
Center Height (Vertical)	mm	160	210	255
Table Height (Horizontal)	mm	-	-	-
Table T-slot Width	mm	12H7	14H7	14H7
Guide Block Width	mm	18h7	18h7	18h7
Min. Increment	deg.	0.001	0.001	0.001
Indexing Precision	sec.	15	15	15
Repeatability	sec.	6	6	6
Clamping System : Hydraulic	MPa (kgf/cm <sup>2</sup> )	3.5 (35)	3.5 (35)	3.5 (35)
Clamping torque ※1	N·m (kgf·m)	687 (70)	1128 (115)	1962 (200)
Servo Motor Type	FANUC	Straight shaft without key	αiF8 / βis12	αiF12 / βis22
	MITSUBISHI	Straight shaft without key	HG - 154	HG - 204
Speed Reduction Ratio	-	1 / 120	1 / 120	1 / 120
Max. Rotation Rate of Table ※2	min <sup>-1</sup>	33.3	25	25
Allowable Inertia Load Capacity (Vertical)	kg·m <sup>2</sup>	1.2	3.1	6.2
Allowable Workpiece Load	Vertical	kg	100	150
	with support table	kg	250	350
	Horizontal	kg	-	-
Allowable Thrust Load (with Rotary Table Clamping)	F	N (kgf)	19620 (2000)	29430 (3000)
	FxL	N·m (kgf·m)	1472 (150)	2943 (300)
	FxL	N·m (kgf·m)	687 (70)	1128 (115)
Driving Torque	N·m (kgf·m)	540 (55)	785 (80)	1668 (170)
Net Weight (without motor)	kg	109	204	286

※1 : If a mechanical brake is not used, this value will correspond to the motor's holding torque.  
 ※2 : The structural limit value, while the actual operating speed will vary depending on the motor.

### HR-255N

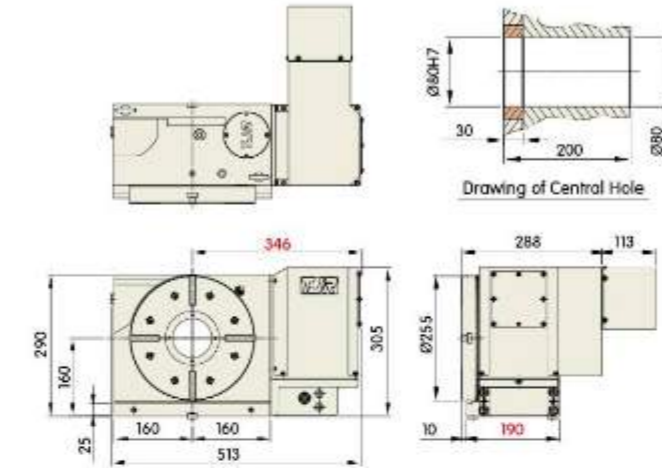

### HR-320N

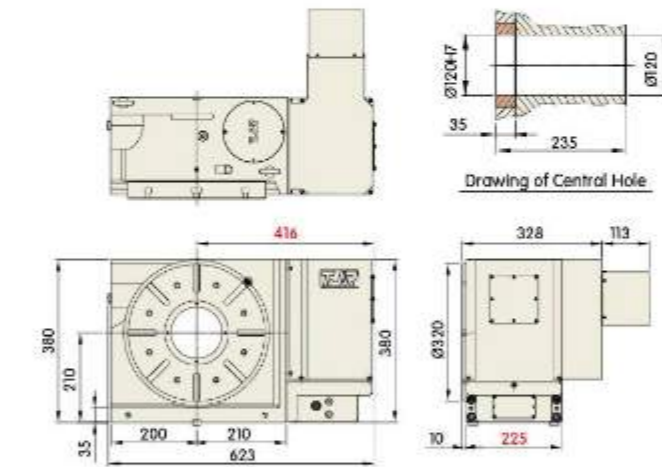

### HR-400N

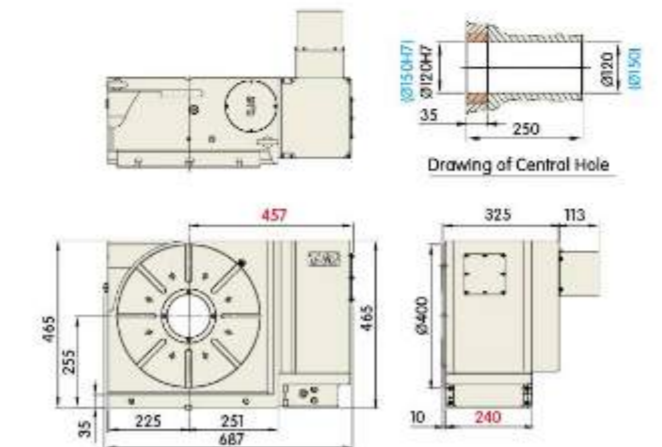

\*1) Ø150 central through hole is available.

## HR Series (Hydraulic Brake)

### HR - 320 B - 2W

Worm Gear Drive with Hydraulic Brake  
(Min. Indexing Angle: 0.001°)

Table Diameter

Back-side Motor; Vertical use

2-Spindle Coupled



Drive by  
Worm & Worm Gear



Use  
radial & axial bearings



Wrap-around Brake

Item / Model	Unit	HR-320B	HR-320B-2W	HR-400B
Table Diameter	mm	Ø320	Ø320	Ø400
Inner Diameter of Mandrel Sleeve	mm	Ø120H7	Ø120H7	Ø120H7
Diameter of Center Through Hole	mm	Ø120x217 deep	Ø120H7x217 deep	Ø120x220 deep
Center Height (Vertical)	mm	255	270	255
Table Height (Horizontal)	mm	-	-	-
Distance between Table Centers	mm	-	400	-
Table T-slot Width	mm	14H7	14H7	14H7
Guide Block Width	mm	18h7	18h7	18h7
Min. Increment	deg.	0.001	0.001	0.001
Indexing Precision	sec.	15	15	15
Repeatability	sec.	6	6	6
Clamping System : Hydraulic	MPa (kgf/cm <sup>2</sup> )	3.5 (35)	3.5 (35)	3.5 (35)
Clamping torque ※1	N·m (kgf·m)	1128 (115)	1128 (115)	1962 (200)
Servo Motor Type	FANUC	Straight shaft without key αiF12 / βis22	αiF12 / βis22	αiF12 / βis22
	MITSUBISHI	Straight shaft without key HG - 204	HG - 204	HG - 204
Speed Reduction Ratio	-	1 / 150	1 / 150	1 / 150
Max. Rotation Rate of Table ※2	min <sup>-1</sup>	25	25	25
Allowable Inertia Load Capacity (Vertical)	kg·m <sup>2</sup>	3.1	3.1	6.2
Allowable Workpiece Load	Vertical	kg	150	200
	with support table	kg	350	500
	Horizontal	kg	-	-
Allowable Thrust Load (with Rotary Table Clamping)	F	N (kgf)	29430 (3000)	39240 (4000)
	FxL	N·m (kgf·m)	2943 (300)	3924 (400)
	FyL	N·m (kgf·m)	1128 (115)	1962 (200)
	FzL	N·m (kgf·m)	785 (80)	1668 (170)
Driving Torque	N·m (kgf·m)	785 (80)	785 (80)	1668 (170)
Net Weight (without motor)	kg	-	-	281

※1 : If a mechanical brake is not used, this value will correspond to the motor's holding torque.  
 ※2 : The structural limit value, while the actual operating speed will vary depending on the motor.

### HR-320B

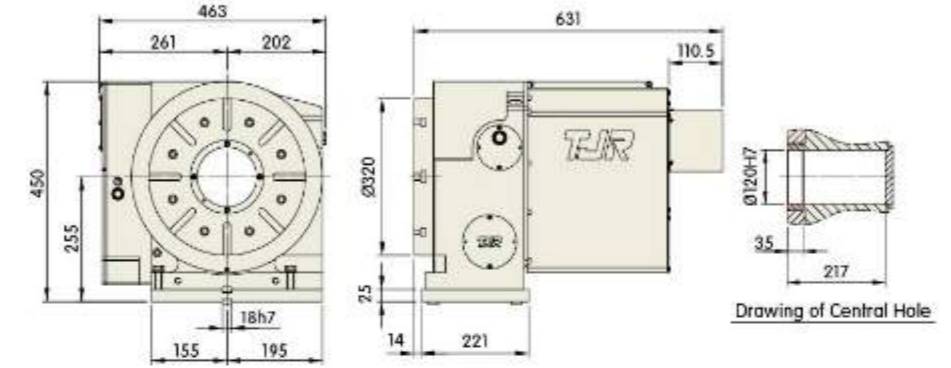

### HR-320B-2W

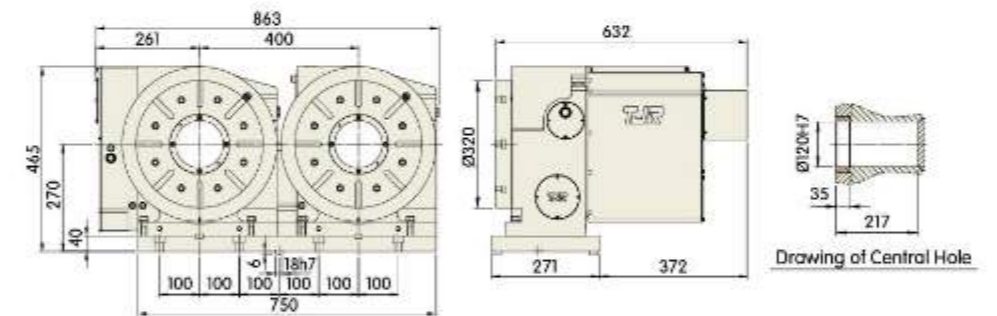

### HR-400B

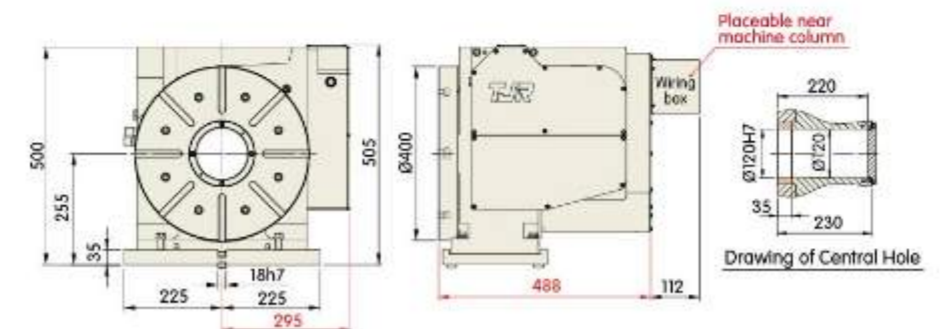

## HR / MTHR Series

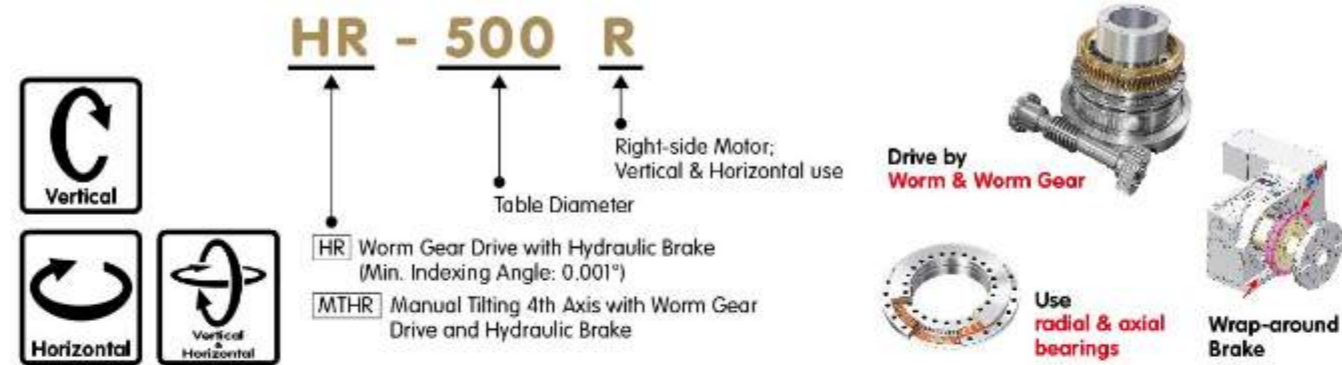

Item / Model	Unit	HR-500R	HR-630R	HR-800R	MTHR-255	
Table Diameter	mm	Ø500	Ø630	Ø800	Ø225	
Inner Diameter of Mandrel Sleeve	mm	Ø220H7	Ø280H7	Ø350H7	Ø80H7	
Diameter of Center Through Hole	mm	Ø220	Ø280	Ø350	Ø80	
Center Height (Vertical)	mm	310	400	470	-	
Table Height (Horizontal)	mm	290	325	350	275	
Table T-slot Width	mm	18H7	18H7	18H7	12H7	
Guide Block Width	mm	18h7	18h7	18h7	18h7	
Min. Increment	deg.	0.001	0.001	0.001	0.001	
Axis	-	-	-	-	Rotation	Tilt 0°~100°
Indexing Precision	sec.	15	15	15	15	-
Repeatability	sec.	6	6	6	6	-
Clamping System : Pne. 0.6(6) / Hyd. 3.5(35)	MPa (kgf/cm <sup>2</sup> )	Hyd.	Hyd.	Hyd.	Hyd.	Dual-lever manual disc brake
Clamping torque (※1)	N·m (kgf·m)	3630 (370)	7848 (800)	7848 (800)	687 (70)	98 (10)
Servo Motor Type	FANUC	Straight shaft without key αiF12 / βis22	αiF12 / βis22	αiF22 / βis30	αiF8 / αiS12 / βis12	Manual
	MITSUBISHI	Straight shaft without key HG - 204	HG - 204	HG - 354	HG - 104	Manual
Speed Reduction Ratio	-	1 / 180	1 / 180	1 / 180	1 / 120	1 / 40
Max. Rotation Rate of Table (※2)	min <sup>-1</sup>	16.7	16.7	11.1	33.3	-
Allowable Inertia Load Capacity (Vertical)	kg·m <sup>2</sup>	11.6	31.2	81.4	2.03	-
Allowable Workpiece Load	Vertical	kg	250	400	800	-
	with support table	kg	600	800	1500	-
	Horizontal	kg	600	800	1500	-
	0° Horizontal	kg	-	-	-	250
	0°~90° Tilt	kg	-	-	-	100
Allowable Thrust Load (with Rotary Table Clamping)	F	N (kgf)	39240 (4000)	49050 (5000)	49050 (5000)	15696 (1600)
	FxL	N·m (kgf·m)	4905 (500)	8339 (850)	9810 (1000)	98 (10)
	FxL	N·m (kgf·m)	3630 (370)	7848 (800)	7848 (800)	687 (70)
	Driving Torque	N·m (kgf·m)	2453 (250)	4120 (420)	7848 (800)	540 (55)
Net Weight (without motor)	kg	405	692	991	145	-

※1 : If no mechanical brake is used, the value equals motor holding torque. Tilting axis brake torque varies with handle force, allowable up to 663 kgf·cm.  
 ※2 : The structural limit value, while the actual operating speed will vary depending on the motor.

### HR-500R

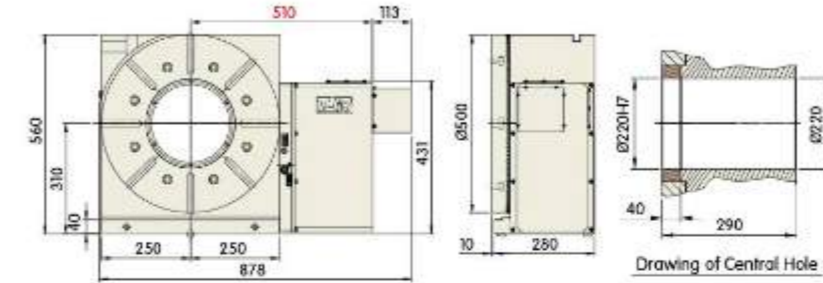

### HR-630R

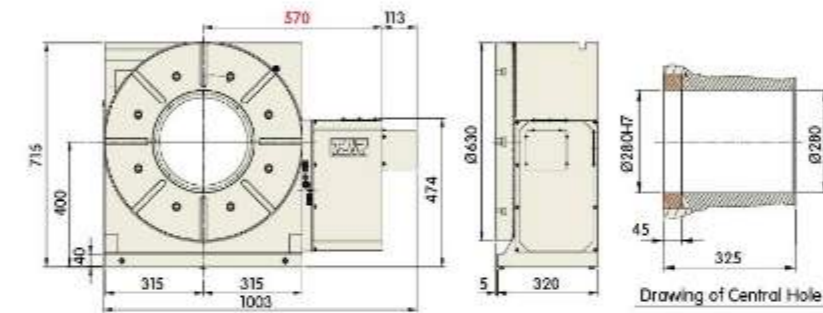

### HR-800R

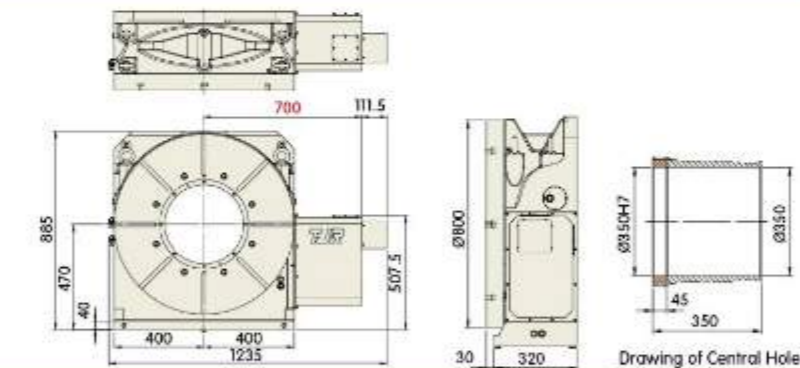

### MTHR-255

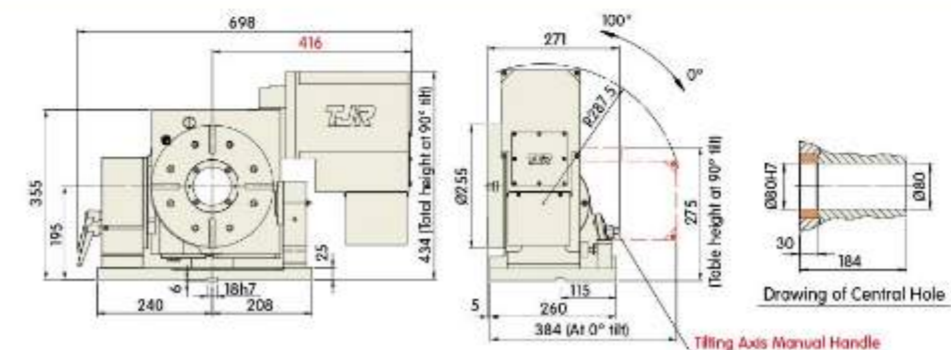



## HI Series

**HI - 255 N**

Hirth Coupling Index Table with Hydraulic Brake  
(Min. Indexing Angle: 1° or 5°)

Table Diameter

Right-side Motor with Compact Cover; Vertical use







Drive by  
**Worm & Worm Gear**

**HI Series:**  
**Three-Piece Clutch Plate Design Advantages:**

- ① Positioning accuracy up to  $\pm 5$  arcseconds. (comparable to angle encoder precision)
- ② Table surface remains flat during rotation, preventing chips or coolant from entering.



Item / Model	Unit	HI-255N	HI-320N	HI-400N	
Table Diameter	mm	Ø255	Ø320	Ø400	
Inner Diameter of Mandrel Sleeve	mm	Ø50H7	Ø80H7	Ø80H7	
Diameter of Center Through Hole	mm	Ø50	Ø80	Ø80	
Center Height (Vertical)	mm	160	210	255	
Table Height (Horizontal)	mm	205	250	255	
Table T-slot Width	mm	12H7	14H7	14H7	
Guide Block Width	mm	18h7	18h7	18h7	
Min. Increment	deg.	1° or 5°	1° or 5°	1° or 5°	
Indexing Precision	sec.	$\pm 5$	$\pm 5$	$\pm 5$	
Repeatability	sec.	$\pm 1$	$\pm 1$	$\pm 1$	
Clamping System : Hydraulic	MPa (kgf/cm <sup>2</sup> )	3.5(35)	3.5(35)	3.5(35)	
Clamping torque	N·m (kgf·m)	2943 (300)	3924 (400)	4905 (500)	
Servo Motor Type	FANUC	Straight shaft without key Bis8	Straight shaft without key Bis22	Straight shaft without key Bis22	
	MITSUBISHI	Straight shaft without key HG - 154	Straight shaft without key HG - 204	Straight shaft without key HG - 204	
Speed Reduction Ratio	-	1 / 120	1 / 120	1 / 120	
Max. Rotation Rate of Table (※1)	min <sup>-1</sup>	33.3	25	25	
Allowable Inertia Load Capacity (Vertical)	kg·m <sup>2</sup>	2.5	4.5	10	
Allowable Workpiece Load	Vertical 	kg	125	175	250
	with support table	kg	250	350	500
	Horizontal 	kg	300	350	500
Allowable Thrust Load (with Rotary Table Clamping)	F 	N (kgf)	15696 (1600)	19620 (2000)	29430 (3000)
	FxL 	N·m (kgf·m)	1717 (175)	2453 (240)	2943 (300)
	FxL 	N·m (kgf·m)	2943 (300)	3924 (400)	4905 (500)
Net Weight (without motor)	kg	120	210	320	

※1 : The structural limit value, while the actual operating speed will vary depending on the motor.

### HI-255N

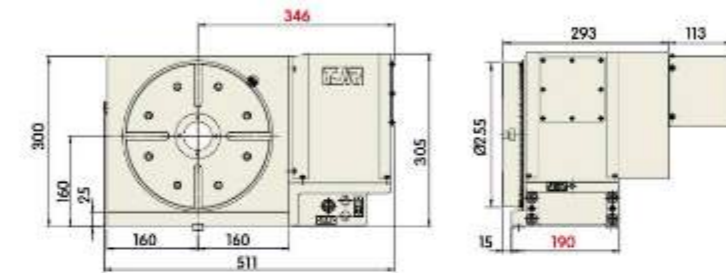
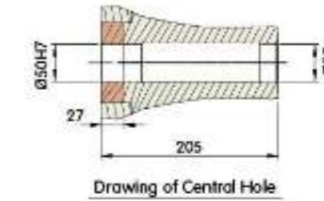

### HI-320N

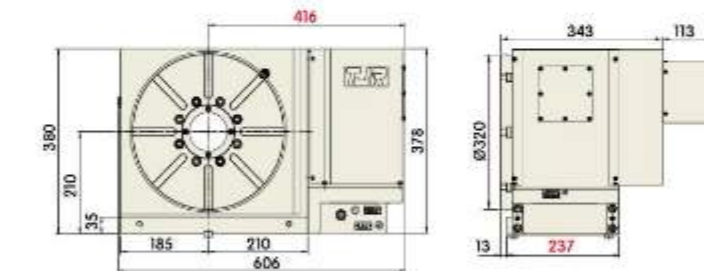
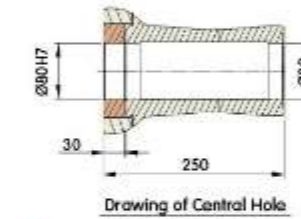

### HI-400N

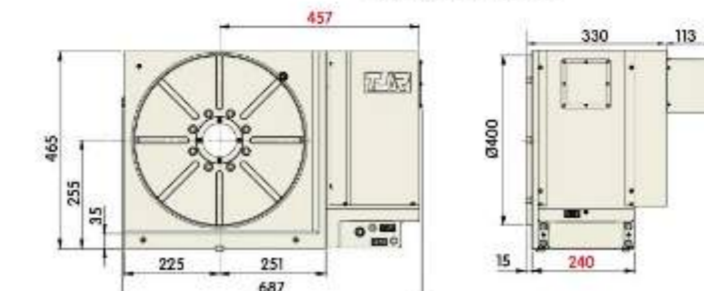
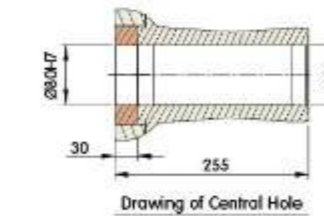

## HHI / HHR Series (Single Indexing Table for Horizontal Machining Centers)

### HHI - 320x320 F

- ↑ **F** Enlarged Faceplate
- ↑ **A** Enhanced Type
- ↑ **HHI** Horizontal Hirth Coupling Index Table with Hydraulic Brake (Min. Indexing Angle: 1° or 5°)
- ↑ **HHR** Horizontal Worm Gear Drive with Hydraulic Brake (Min. Indexing Angle: 0.001°)



Drive by  
**Worm & Worm Gear**

**HHI/HHR Series:**  
**Three-Piece Clutch Plate Design Advantages:**

- ① Positioning accuracy up to ±5 arcseconds. (comparable to angle encoder precision)
- ② Table surface remains flat during rotation, preventing chips or coolant from entering.

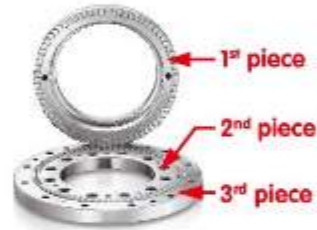

Item / Model	Unit	HHI-320x320F	HHI-400x400A	HHI-500x500	HHR-400x400	HHR-500x500	
Table Size	mm	□320x320	□400x400	□500x500	□400x400	□500x500	
Inner Diameter of Mandrel Sleeve	mm	Ø50H7x27 deep	Ø50H7x27 deep	Ø50H7x27 deep	Ø50H7x27 deep	Ø50H7x27 deep	
Table Height (Horizontal)	mm	240	270	320	282.5	295	
Table T-slot Width	mm	-	14H7	18H7	-	18H7	
Guide Block Width	mm	18h7	18h7	18h7	18h7	18h7	
Min. Increment	deg.	1° or 5°	1° or 5°	1° or 5°	0.001	0.001	
Indexing Precision	sec.	±5	±5	±5	20	15	
Repeatability	sec.	±1	±1	±1	6	6	
Clamping System : Hydraulic	MPa (kgf/cm <sup>2</sup> )	3.5(35)	3.5(35)	3.5(35)	4.5(45)	4.5(45)	
Clamping torque	N·m (kgf·m)	2943 (300)	4905 (500)	9810 (1000)	1521 (155)	3630 (370)	
Servo Motor Type	FANUC	Straight shaft without key	βis12	βis22	βis22	αiF12 / βis22	
	MITSUBISHI	Straight shaft without key	HG - 154	HG - 204	HG - 204	HG - 204	
Speed Reduction Ratio	-	1 / 120	1 / 120	1 / 180	1 / 120	1 / 180	
Max. Rotation Rate of Table (※1)	min <sup>-1</sup>	25.0	25	16.7	25	16.7	
Allowable Inertia Load Capacity	kg·m <sup>2</sup>	5	16	50	13	25	
Allowable Workpiece Load	Horizontal	kg	300	600	1200	500	
Allowable Thrust Load (with Rotary Table Clamping)	F	N (kgf)	15696 (1600)	29430 (3000)	39240 (4000)	24525 (2500)	39240 (4000)
	FxL	N·m (kgf·m)	1717 (175)	2943 (300)	5886 (600)	2943 (300)	4905 (500)
	FxL	N·m (kgf·m)	2943 (300)	4905 (500)	9810 (1000)	1521 (155)	3630 (370)
Driving Torque	N·m (kgf·m)	-	-	-	1668 (170)	2453 (250)	
Net Weight (without motor)	kg	149	-	518	405	405	

※1 : The structural limit value, while the actual operating speed will vary depending on the motor.

### HHI-320x320F (1° or 5°)

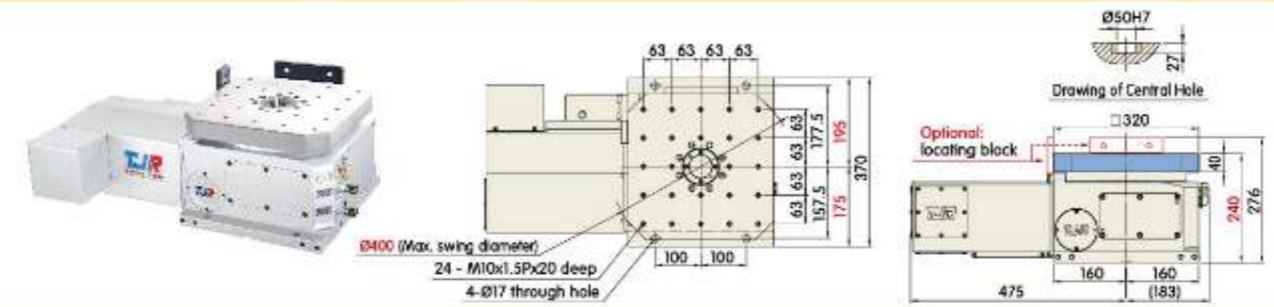

### HHI-400x400A (1° or 5°)

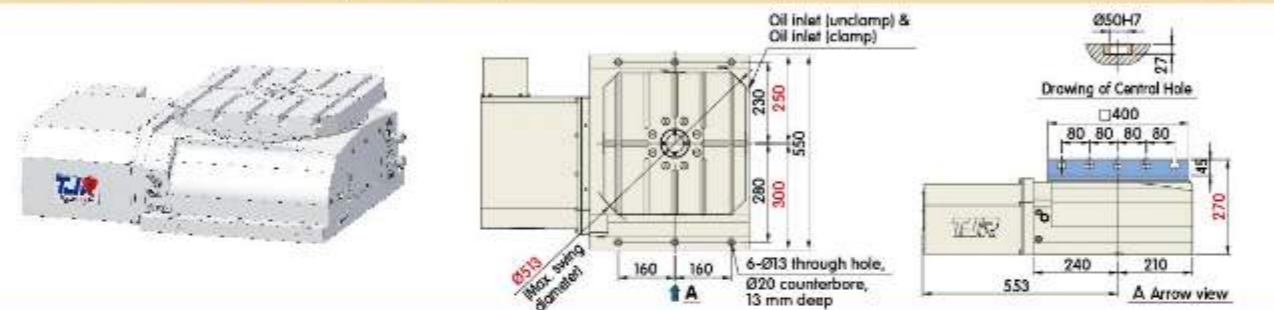

### HHI-500x500 (1° or 5°)

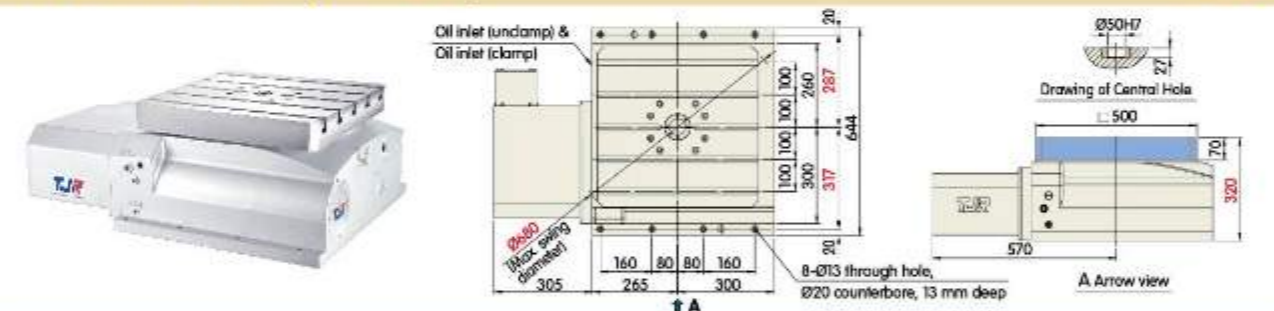

### HHR-400x400 (0.001°)

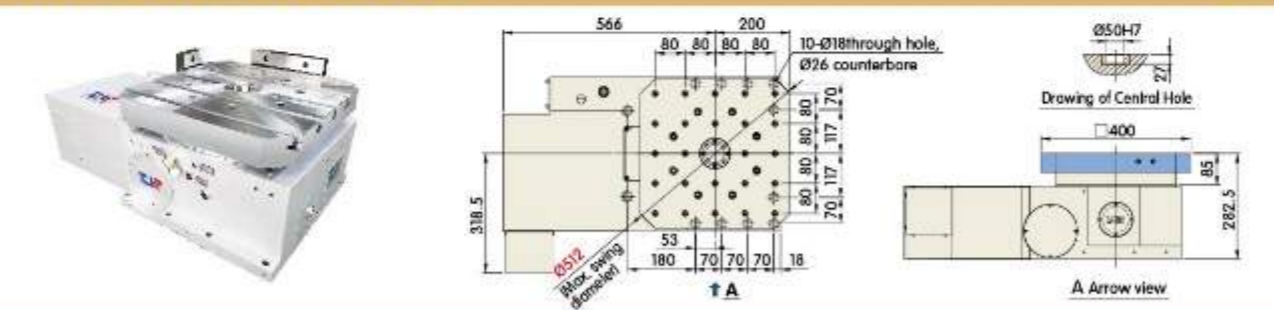

### HHR-500x500 (0.001°)

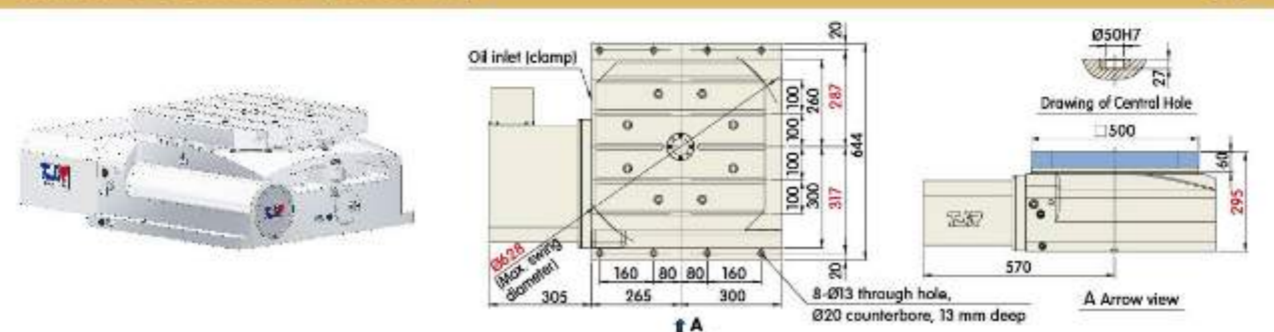

Driven by  
Worm & Worm Gear

## HHI Series (Single Indexing Table for Horizontal Machining Centers)

### HHI - 630x630

Horizontal Hirth Coupling Index Table with Hydraulic Brake  
(Min. Indexing Angle: 1° or 5°)



Drive by  
Worm & Worm Gear

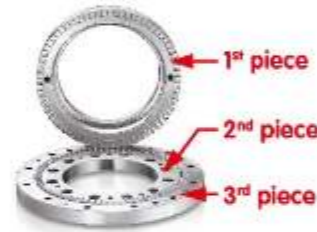

**HHI Series:**  
**Three-Piece Clutch Plate Design Advantages:**

- ① Positioning accuracy up to  $\pm 5$  arcseconds, (comparable to angle encoder precision)
- ② Table surface remains flat during rotation, preventing chips or coolant from entering.



Item / Model	Unit	HHI-630x630	HHI-800x800	HHI-1000x1000
Table Size	mm	□ 630x630	□ 800x800	□ 1000x1000
Inner Diameter of Mandrel Sleeve	mm	Ø50H7x27 deep	Ø50H7x27 deep	Ø50H7x27 deep
Table Height (Horizontal)	mm	350	380	400
Table T-slot Width	mm	18H7	22H7	22H7
Guide Block Width	mm	18h7	18h7	18h7
Min. Increment	deg.	1° or 5°	1° or 5°	1° or 5°
Indexing Precision	sec.	±5	±5	±5
Repeatability	sec.	±1	±1	±1
Clamping System : Hydraulic	MPa (kgf/cm <sup>2</sup> )	3.5(35)	3.5(35)	3.5(35)
Clamping torque	N·m (kgf·m)	11772 (1200)	39240 (4000)	51993 (5300)
Servo Motor Type	FANUC	Straight shaft without key Bis22	Bis22	Bis30
	MITSUBISHI	Straight shaft without key HG - 204	HG - 204	HG - 354
Speed Reduction Ratio	-	1 / 180	1 / 180	1 / 360
Max. Rotation Rate of Table (※1)	min <sup>-1</sup>	16.7	11.1	5.6
Allowable Inertia Load Capacity	kg·m <sup>2</sup>	119	427	833
Allowable Workpiece Load	kg	1800	4000	5000
Allowable Thrust Load (with Rotary Table Clamping)	F	N (kgf)	58860 (6000)	88290 (9000)
	FxL	N·m (kgf·m)	6377 (650)	19130 (1950)
	FxL	N·m (kgf·m)	11772 (1200)	39240 (4000)
Net Weight (without motor)	kg	565	1053	1971

※1 : The structural limit value, while the actual operating speed will vary depending on the motor.

### HHI-630x630 (1° or 5°)

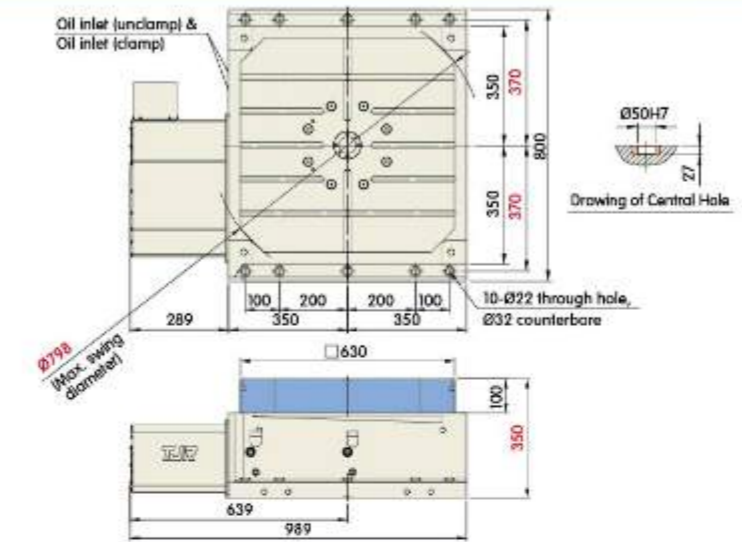

### HHI-800x800 (1° or 5°)

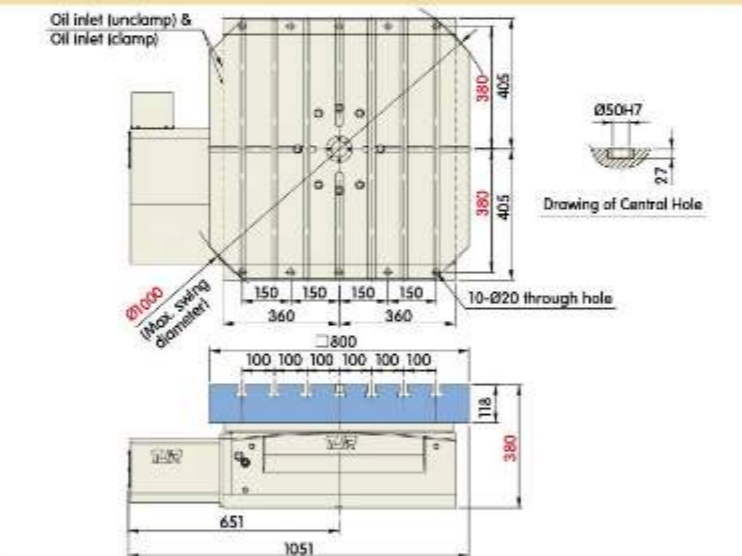

### HHI-1000x1000 (1° or 5°)

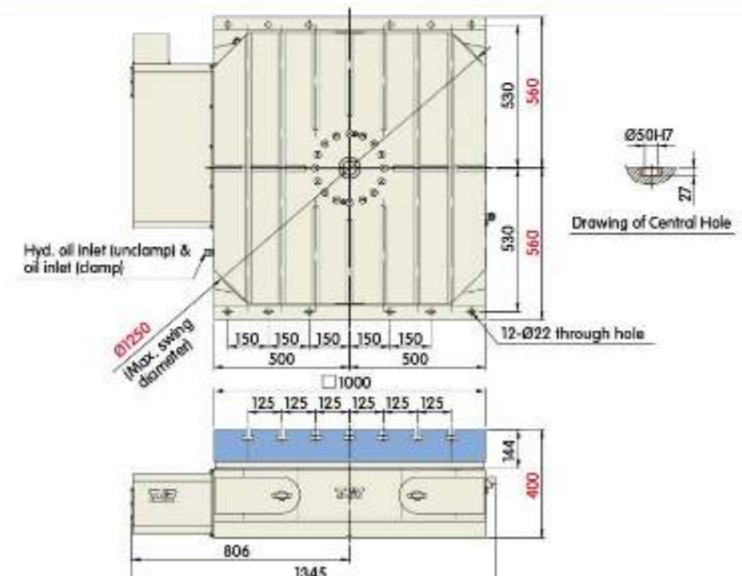

## FAR Series (Pneumatic Brake)

### FAR - 170 H B

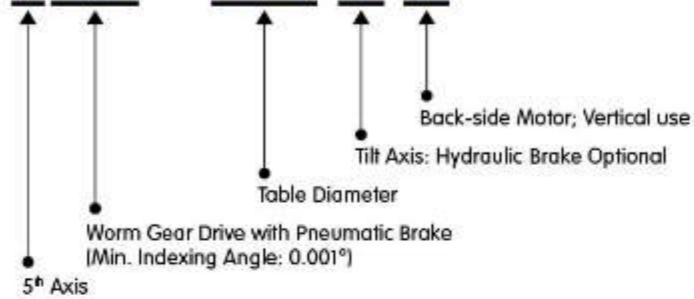

Drive by Alloy Steel Worm Gear Use radial & axial bearings



Item / Model		Unit	FARs-125 / 125B		FAR-170(H) / 170(H)B	
Table Diameter		mm	Ø125		Ø170	
Inner Diameter of Mandrel Sleeve		mm	Ø35H7		Ø40H7	
Diameter of Center Through Hole		mm	Ø25		Ø40	
Table Height (Horizontal)		mm	215		270	
Table T-slot Width		mm	12H7		12H7	
Guide Block Width		mm	14h7		18h7	
Min. Increment		deg.	0.001		0.001	
Axis		-	Rotation	Tilt (-30°~+120°)	Rotation	Tilt ±100°
Indexing Precision		sec.	40	60	20	60
Repeatability		sec.	6	8	6	8
Clamping System : Pne. 0.6(6) / Hyd. 3.5(35)		MPa (kgf/cm <sup>2</sup> )	Pne.	Pne.	Pne.	Pne. Hyd.
Clamping torque [※1]		N·m (kgf·m)	128 (13)	304 (31)	304 (31)	304 (31) 540 (55)
Servo Motor Type	FANUC	Straight shaft without key	aiS4 / Bis4	aiF4 / Bis8	aiF4 / Bis8	aiF8 / ais12 / Bis12
	MITSUBISHI	Straight shaft without key	HG - 75 / 105	HG - 54 / 104	HG / HF - 54 / 104	HG / HF - 104
Speed Reduction Ratio		-	1 / 60	1 / 90	1 / 90	1 / 90
Max. Rotation Rate of Table [※2]		min <sup>-1</sup>	33.3	33.3	33.3	25
Allowable Inertia Load Capacity (Horizontal)		kg·m <sup>2</sup>	0.1		0.27	
Allowable Workpiece Load	0° Horizontal	kg	50		75	
	0°~90° Tilt	kg	35		50	
Allowable Thrust Load (with Rotary Table Clamping)	F	N (kgf)	3924 (400)		7358 (750)	
	FxL	N·m (kgf·m)	304 (31)		304 (31)	
	FyL	N·m (kgf·m)	128 (13)		304 (31)	
	FzL	N·m (kgf·m)	36 (3.7)		284 (29)	
Driving Torque		N·m (kgf·m)	36 (3.7)		284 (29)	
Net Weight (without motor)		kg	97	107	153	163

※1 : If a mechanical brake is not used, this value will correspond to the motor's holding torque.  
 ※2 : The structural limit value, while the actual operating speed will vary depending on the motor.

### FARs-125

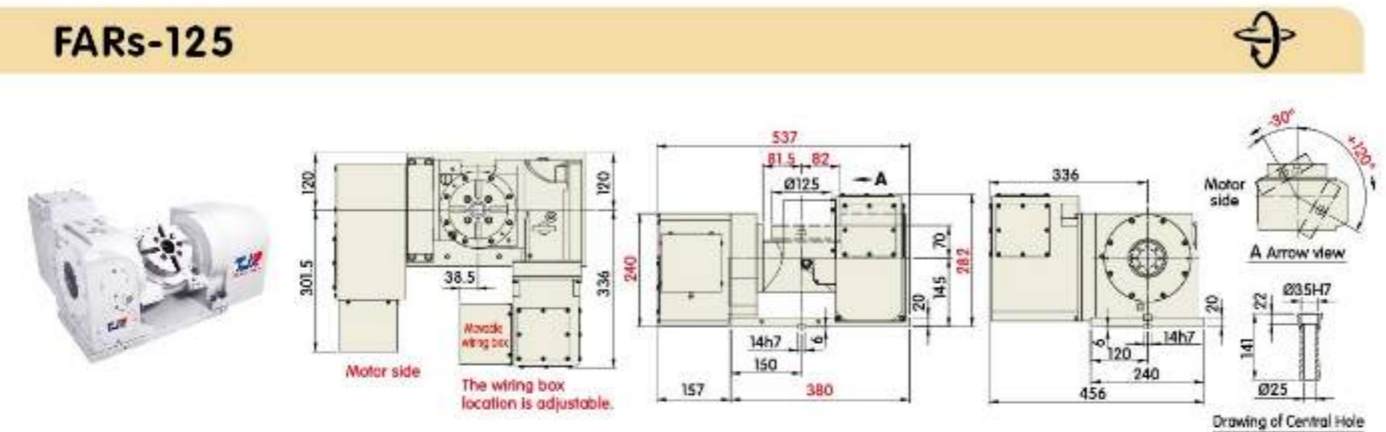

### FARs-125B

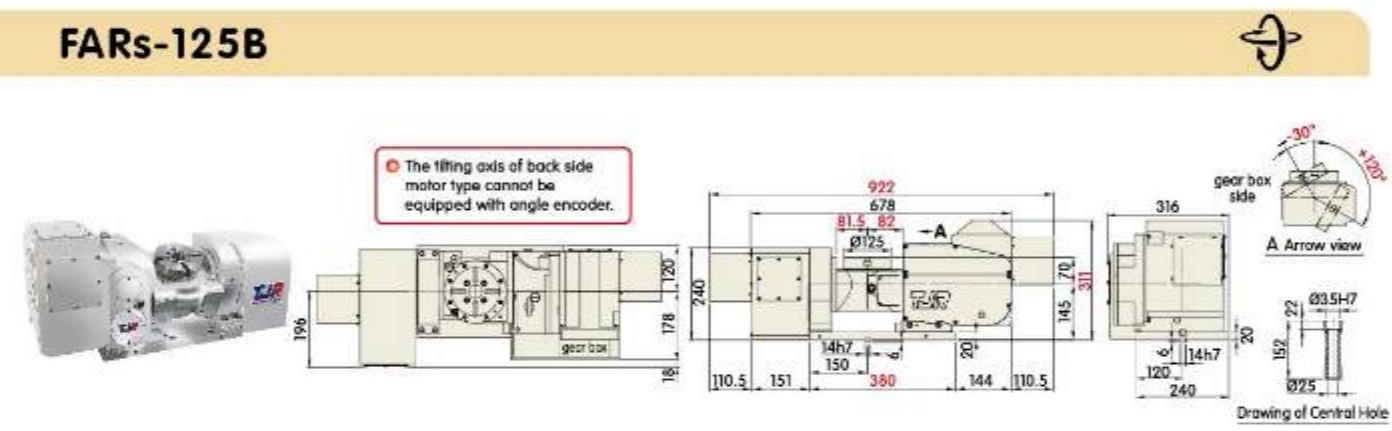

### FAR-170(H)

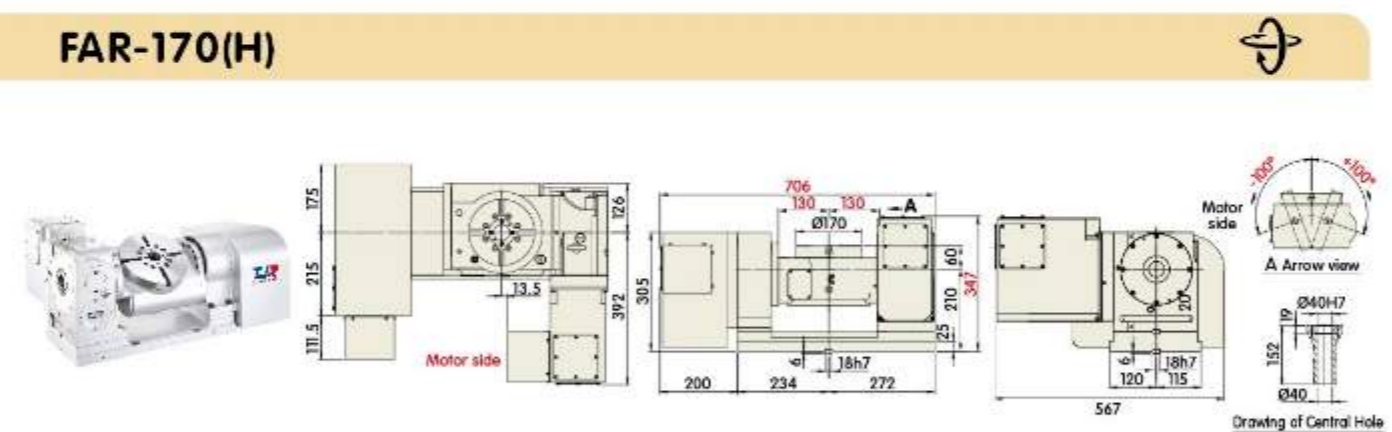

### FAR-170(H)B

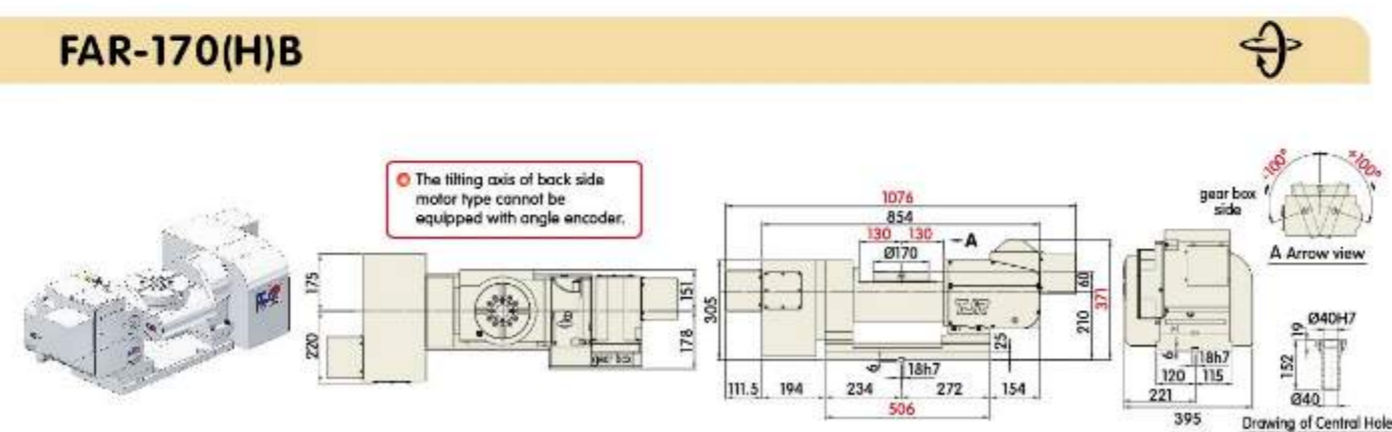

Driven by Worm & Worm Gear

## FAR Series (Pneumatic Brake)

### FAR - 160 SN H - RC255 N

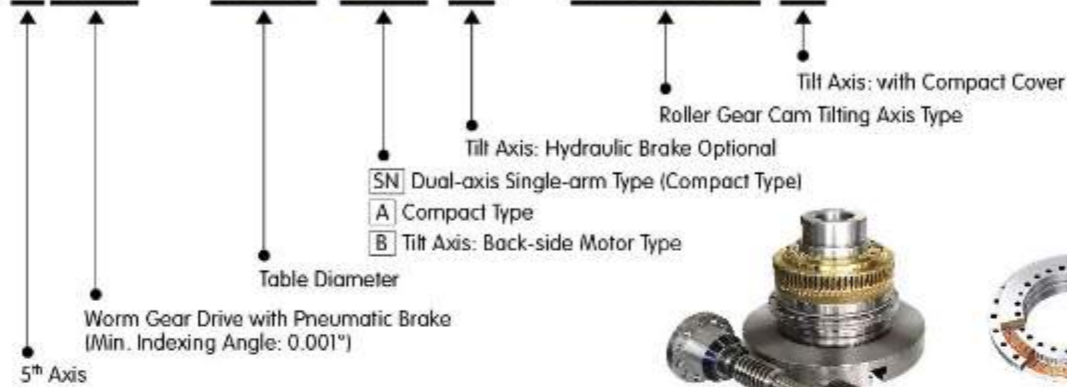

Drive by **Worm & Worm Gear** Use **radial & axial bearings**

Item / Model	Unit	FARs-160SN-RC255N		FAR-170A(H)		FAR-210(H) / 210B(H)			
Table Diameter	mm	Ø160		Ø170		Ø210			
Inner Diameter of Mandrel Sleeve	mm	Ø35H7		Ø40H7		Ø40H7			
Diameter of Center Through Hole	mm	Ø25		Ø40		Ø35			
Table Height (Horizontal)	mm	230		245		270			
Table T-slot Width	mm	12H7		12H7		12H7			
Guide Block Width	mm	18h7		18h7		18h7			
Min. Increment	deg.	0.001		0.001		0.001			
Axis	-	Rotation	Tilt ±110°	Rotation	Tilt ±100°	Rotation	Tilt ±100°		
Indexing Precision	sec.	40	60	20	60	20	60		
Repeatability	sec.	6	8	6	8	6	8		
Clamping System : Pne. 0.6(6) / Hyd. 3.5(35)	MPa (kgf/cm <sup>2</sup> )	Pne.	Hyd.	Pne.	Pne.	Hyd.	Pne.	Pne.	Hyd.
Clamping torque (※1)	N·m (kgf·m)	128 (13)	687 (70)	245 (25)	304 (31)	540 (55)	304 (31)	304 (31)	540 (55)
Servo Motor Type	FANUC	Straight shaft without key		αiS4 / Bis4	αiS12 / Bis12	αiS4 / Bis4	αiF4 / Bis8	αiF4 / Bis8	αF8 / αS12 / Bis12
	MITSUBISHI	Straight shaft without key		HG - 56	HG - 154	HG - 75 / 105	HG - 54 / 104	HG - 54 / 104	HG - 104
Speed Reduction Ratio	-	1 / 60	1 / 60	1 / 72	1 / 90	1 / 90	1 / 90	1 / 90	
Max. Rotation Rate of Table (※2)	min <sup>-1</sup>	33.3	50	33.3	25	33.3	25	25	
Allowable Inertia Load Capacity (Horizontal)	kg·m <sup>2</sup>	0.1		0.22		0.27			
Allowable Workpiece Load	0° Horizontal	kg		25		60		75	
	0°~90° Tilt	kg		20		40		50	
Allowable Thrust Load (with Rotary Table Clamping)	F	N (kgf)		5886 (600)		5886 (600)		7358 (750)	
	FxL	N·m (kgf·m)		687 (70)		304 (31) 540 (55)		304 (31)	
	FyL	N·m (kgf·m)		128 (13)		245 (25)		304 (31)	
Driving Torque	N·m (kgf·m)	36 (3.7)		177 (18)		284 (29)			
Net Weight (without motor)	kg	126		125		153 163			

※1 : If a mechanical brake is not used, this value will correspond to the motor's holding torque.  
 ※2 : The structural limit value, while the actual operating speed will vary depending on the motor.

### FARs-160SN-RC255N

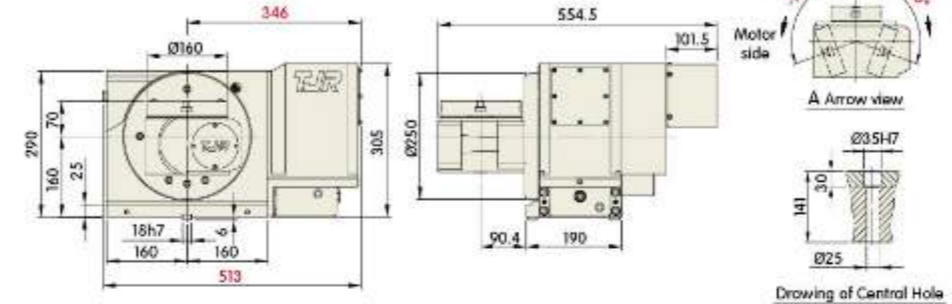

### FAR-170A(H)

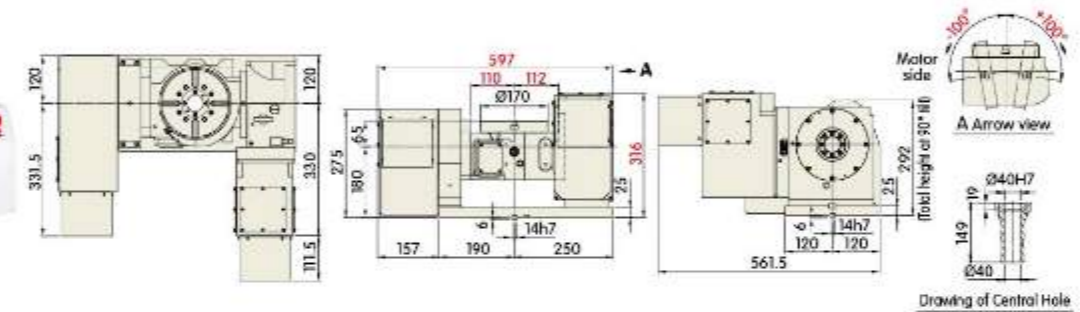

### FAR-210(H)

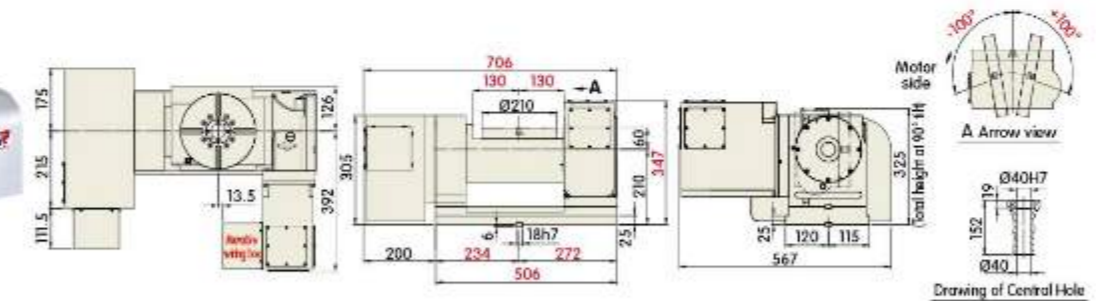

### FAR-210B(H)

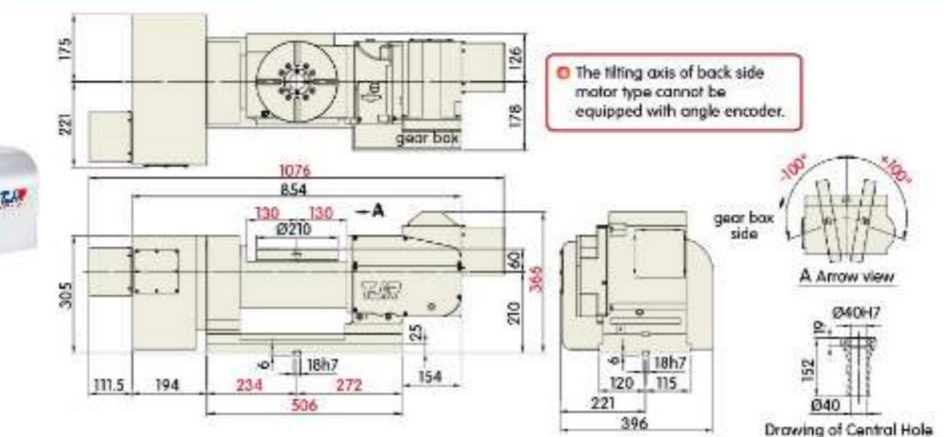

## FHR Series (Hydraulic Brake)

### FHR - 255 C L

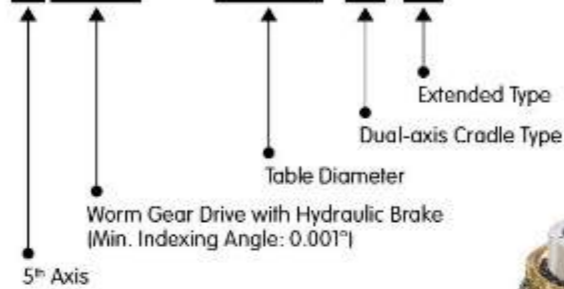

Drive by  
Worm & Worm Gear



Use  
radial & axial bearings



Wrap-around Brake



Item / Model	Unit	FHR-255C / 255CL		FHR-320		FHR-320C		
Table Diameter	mm	Ø255		Ø320		Ø320		
Inner Diameter of Mandrel Sleeve	mm	Ø80H7		Ø120H7		Ø120H7x30 deep		
Diameter of Center Through Hole	mm	Ø80		Ø120		Ø80		
Table Height (Horizontal)	mm	290		355		310		
Table T-slot Width	mm	12H7		14H7		14H7		
Guide Block Width	mm	18h7		18h7		18h7		
Min. Increment	deg.	0.001		0.001		0.001		
Axis	-	Rotation	Tilt ±110°	Rotation	Tilt ±110°	Rotation	Tilt ±110°	
Indexing Precision	sec.	15	60	15	50	15	60	
Repeatability	sec.	6	8	6	8	6	8	
Clamping System : Hydraulic	MPa (kgf/cm <sup>2</sup> )	3.5 (35)	3.5 (35)	3.5 (35)	3.5 (35)	3.5 (35)	3.5 (35)	
Clamping torque ※1	N·m (kgf·m)	687 (70)	1373 (140)	1128 (115)	1717 (175)	687 (70)	1717 (175)	
Servo Motor Type	FANUC	Straight shaft without key	αiF8 / αiS12 / Bis12	αiF8 / αiS12 / Bis12	αiF8 / αiS12 / Bis12	αiF12 / Bis22	αF8 / αiS12 / Bis12	αiF12 / Bis22
	MITSUBISHI	Straight shaft without key	HG - 104	HG - 154	HG - 104	HG - 204	HG - 104	HG - 204
Speed Reduction Ratio	-	1 / 120	1 / 120	1 / 120	1 / 120	1 / 120	1 / 120	
Max. Rotation Rate of Table ※2	min <sup>-1</sup>	33.3	16.6	25	16.6	25	16.6	
Allowable Inertia Load Capacity (Horizontal)	kg·m <sup>2</sup>	0.8		2.6		2.6		
Allowable Workpiece Load	0° Horizontal	kg		200		200		
	0°~90° Tilt	kg		150		100		
Allowable Thrust Load (with Rotary Table Clamping)	F	N (kgf)	14715 (1500)	17658 (1800)	17658 (1800)	1717 (175)	1717 (175)	
	FxL	N·m (kgf·m)	1373 (140)	1717 (175)	1717 (175)	687 (70)	687 (70)	
	FyL	N·m (kgf·m)	687 (70)	1128 (115)	1128 (115)	687 (70)	687 (70)	
	FzL	N·m (kgf·m)	540 (55)	785 (80)	785 (80)	540 (55)	540 (55)	
Driving Torque	N·m (kgf·m)	540 (55)		785 (80)		540 (55)		
Net Weight (without motor)	kg	296	312	470	470	489	489	

※1 : If a mechanical brake is not used, this value will correspond to the motor's holding torque.  
 ※2 : The structural limit value, while the actual operating speed will vary depending on the motor.

### FHR-255C

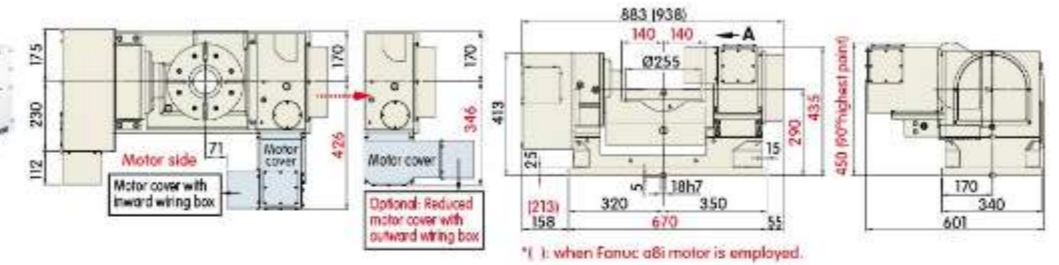

\*1 : when Fanuc αBi motor is employed.

### FHR-255CL

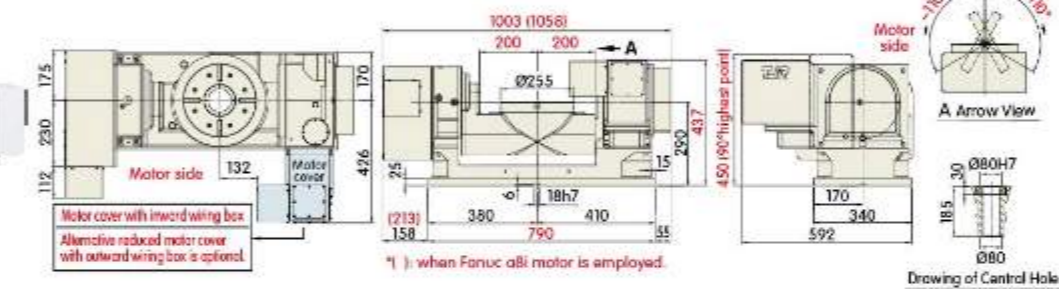

\*1 : when Fanuc αBi motor is employed.

Drawing of Control Hole

### FHR-320

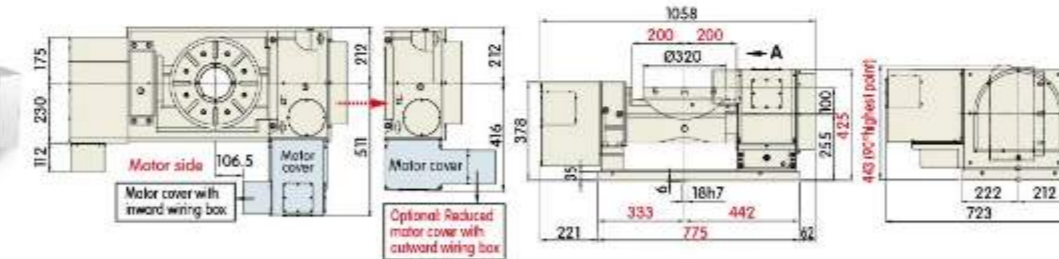

### FHR-320C

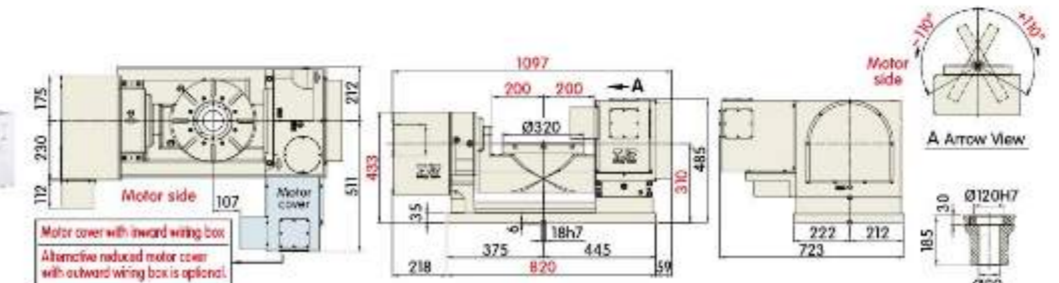

Drawing of Control Hole

## FHR Series (Hydraulic Brake)

### FHR - 400 C F - 540 - HR400B



Drive by  
Worm & Worm Gear

Use  
radial & axial bearings

Wrap-around Brake

Item / Model	Unit	FHR-400CF		FHR-400C-540-HR400B		FHR-401C-820-HR400B	
Table Diameter	mm	Ø400		Ø400		Ø400	
Inner Diameter of Mandrel Sleeve	mm	Ø120H7		Ø120H7		Ø120H7	
Diameter of Center Through Hole	mm	Ø120		Ø120		Ø105	
Table Height (Horizontal)	mm	430		380		380	
Table T-slot Width	mm	14H7		14H7		14H7	
Guide Block Width	mm	18h7		18h7		18h7	
Min. Increment	deg.	0.001		0.001		0.001	
Axis	-	Rotation	Tilt ±110°	Rotation	Tilt ±110°	Rotation	Tilt ±110°
Indexing Precision	sec.	15	60	15	60	15	60
Repeatability	sec.	6	8	6	8	6	8
Clamping System : Hydraulic	MPa (kgf/cm <sup>2</sup> )	3.5 (35)	3.5 (35)	3.5 (35)	3.5 (35)	3.5 (35)	3.5 (35)
Clamping torque [※1]	N·m (kgf·m)	1128 (115)	1717 (175)	1128 (115)	2698 (275)	1128 (115)	2698 (275)
Servo Motor Type	FANUC	Straight shaft without key αiF8 / αiS12 / βis12		αiF12 / βis22		αiS12 / βis12	
	MITSUBISHI	HG - 154		HG - 354		HG - 354	
Speed Reduction Ratio	-	1 / 120	1 / 120	1 / 120	1 / 120	1 / 120	1 / 120
Max. Rotation Rate of Table [※2]	min <sup>-1</sup>	25	16.6	25	16.6	25	16.6
Allowable Inertia Load Capacity (Horizontal)	kg·m <sup>2</sup>	4		4.4		4.4	
Allowable Workpiece Load	0° Horizontal	200		220		220	
	0°-90° Tilt	100		120		120	
Allowable Thrust Load (with Rotary Table Clamping)	F	17658 (1800)		17658 (1800)		17658 (1800)	
	FxL	1717 (175)		2698 (275)		2698 (275)	
	FyL	1128 (115)		1128 (115)		1128 (115)	
	FzL	1128 (115)		1128 (115)		1128 (115)	
Driving Torque	N·m (kgf·m)	785 (80)		785 (80)		785 (80)	
Net Weight (without motor)	kg	818		702		958	

※1 : If a mechanical brake is not used, this value will correspond to the motor's holding torque.  
 ※2 : The structural limit value, while the actual operating speed will vary depending on the motor.

### FHR-400CF

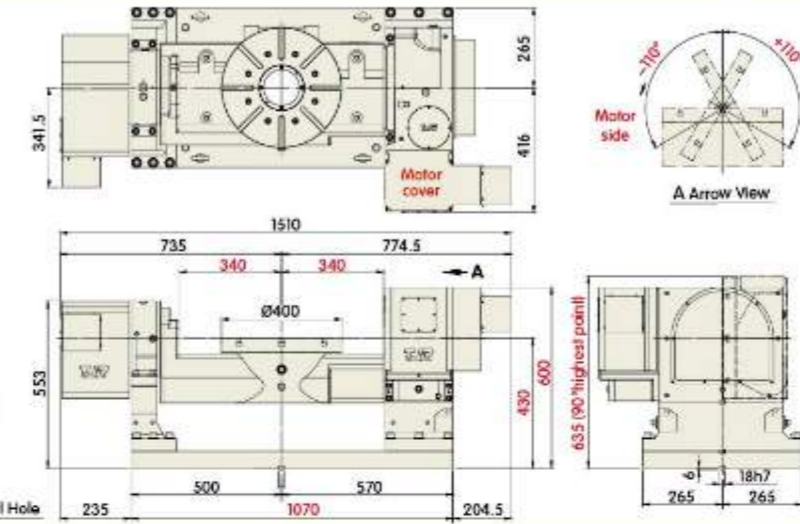
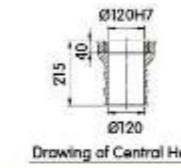

### FHR-400C-540-HR400B



A 4-port rotary joint and an angle encoder can be accommodated at the same time.

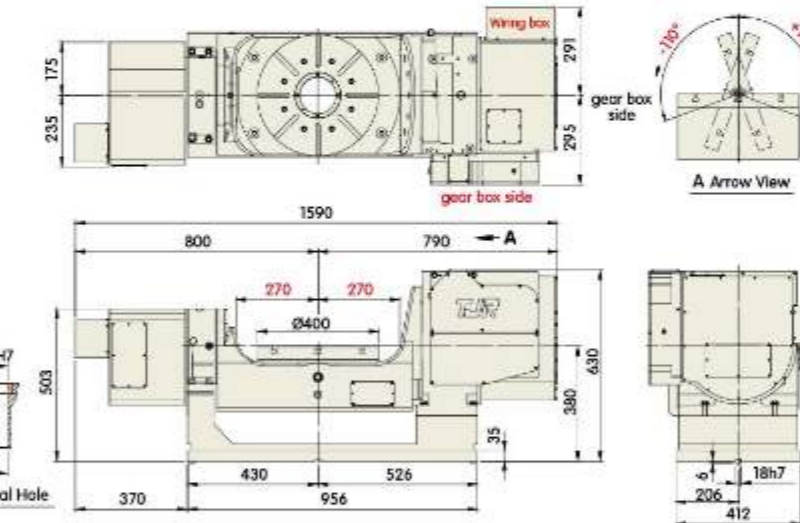

### FHR-401C-820-HR400B



4-port rotary joint can be accommodated.

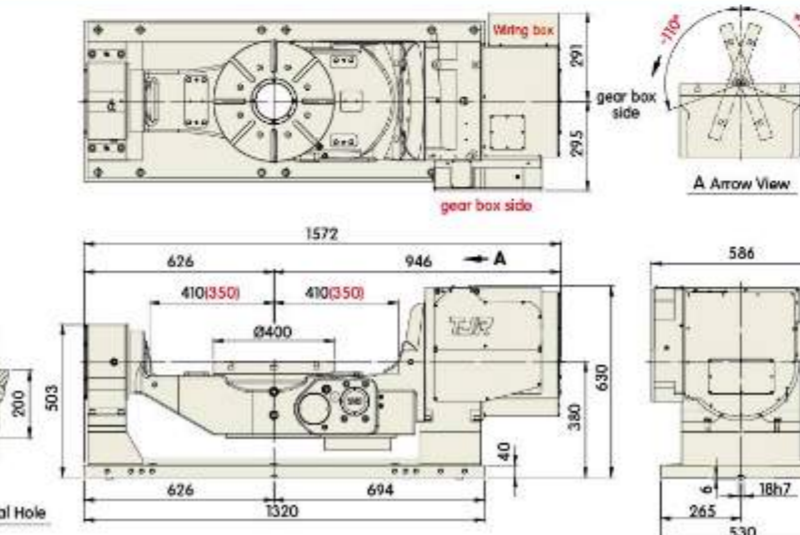

## FHR Series (Hydraulic Brake)

### FHR - 500 C - 550

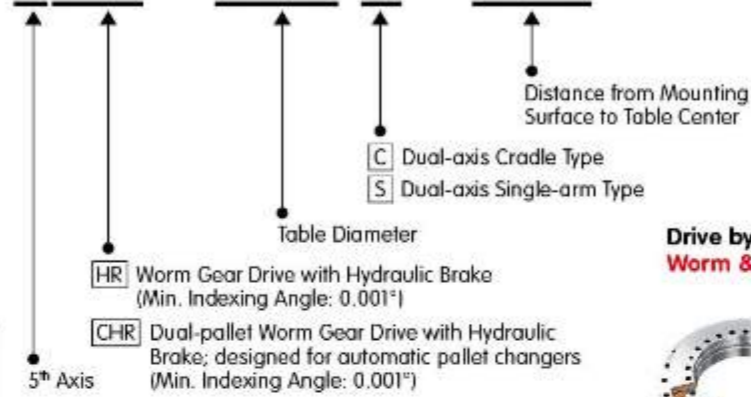

Item / Model	Unit	FHR-500C		FHR-650C		FCHR-650S-550	
Table Diameter	mm	Ø500		Ø400		Ø650	
Inner Diameter of Mandrel Sleeve	mm	Ø220H7		Ø120H7		Ø50H7x27 deep	
Diameter of Center Through Hole	mm	Ø220		Ø120		-	
Table Height (Horizontal)	mm	440		430		-	
Table T-slot Width	mm	18H7		18H7		18H7	
Guide Block Width	mm	18h7		18h7		-	
Min. Increment	deg.	0.001		0.001		0.001	
Axis	-	Rotation	Tilt ±110°	Rotation	Tilt ±110°	Rotation	Tilt ±110°
Indexing Precision	sec.	15	60	15	60	15	60
Repeatability	sec.	6	8	6	8	6	8
Clamping System : Hydraulic	MPa (kgf/cm <sup>2</sup> )	3.5 (35)	3.5 (35)	3.5 (35)	3.5 (35)	3.5 (35)	3.5 (35)
Clamping torque (※1)	N·m (kgf·m)	3630 (370)	4022 (410)	3630 (370)	7848 (800)	3630 (370)	4905 (500)
Servo Motor Type	FANUC	aiF12 / Bis22	aiF22 / Bis30	aiF12 / Bis22	aiF30 / Bis40	aiF22	aiF40
	MITSUBISHI	HG - 204	HG - 354	HG - 204	HG - 703	HG - 204	HG - 703
Speed Reduction Ratio	-	1 / 120	1 / 180	1 / 120	1 / 180	1 / 120	1 / 150
Max. Rotation Rate of Table (※2)	min <sup>-1</sup>	25	11.1	25	11.1	25	13.3
Allowable Inertia Load Capacity (Horizontal)	kg·m <sup>2</sup>	9.4		15.5		15.5	
Allowable Workpiece Load	0° Horizontal	500		500		250	
	0°~90° Tilt	300		400		250	
Allowable Thrust Load (with Rotary Table Clamping)	F	29430 (3000)		31392 (3200)		31392 (3200)	
	FxL	4022 (410)		7848 (800)		4905 (500)	
	FyL	3630 (370)		3630 (370)		3630 (370)	
	FzL	2453 (250)		2453 (250)		2453 (250)	
Driving Torque	N·m (kgf·m)	2453 (250)		2453 (250)		2453 (250)	
Net Weight (without motor)	kg	1091		1867		1434	

※1 : If a mechanical brake is not used, this value will correspond to the motor's holding torque.  
 ※2 : The structural limit value, while the actual operating speed will vary depending on the motor.

## FHR-500C

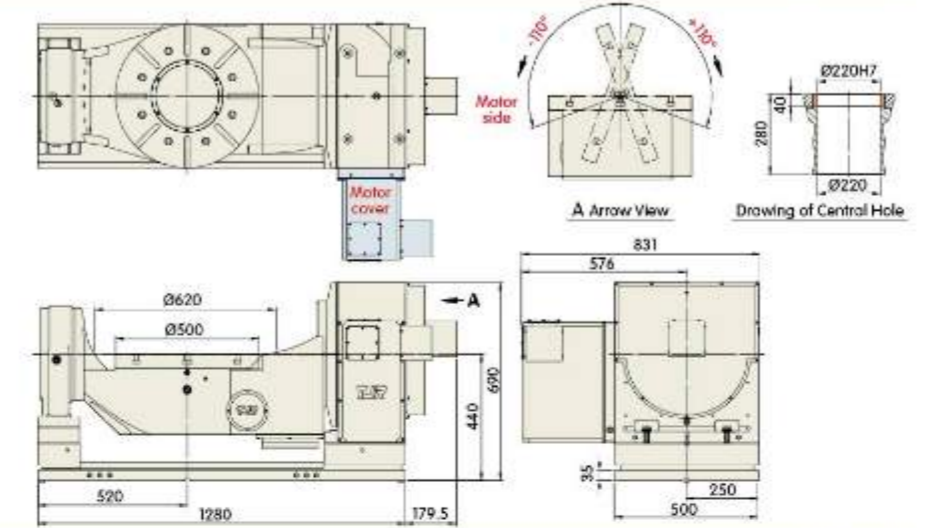

## FHR-650C

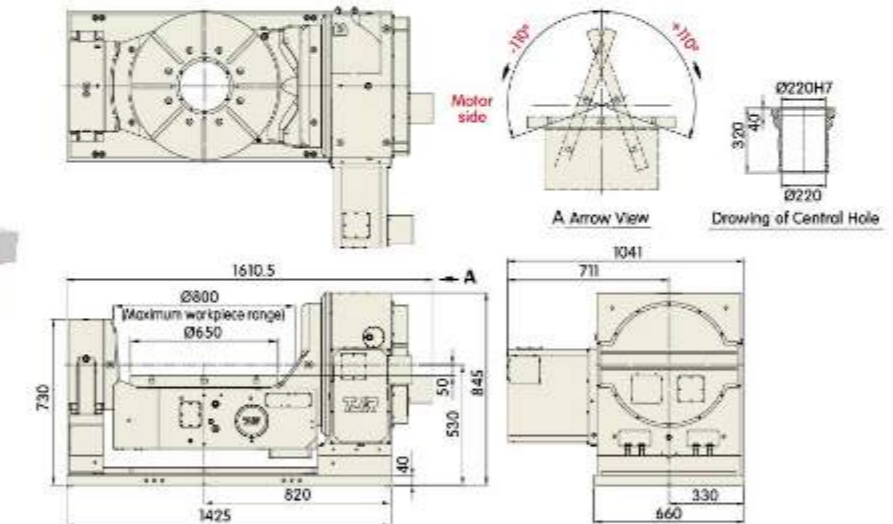

## FCHR-650S-550



(Pallet change type)

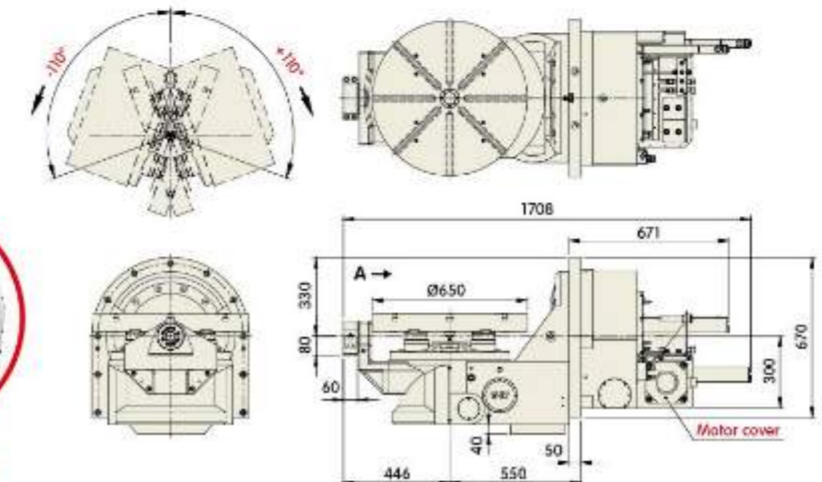

## FHR Series (Hydraulic Brake)

### FHR - 650 S - 525

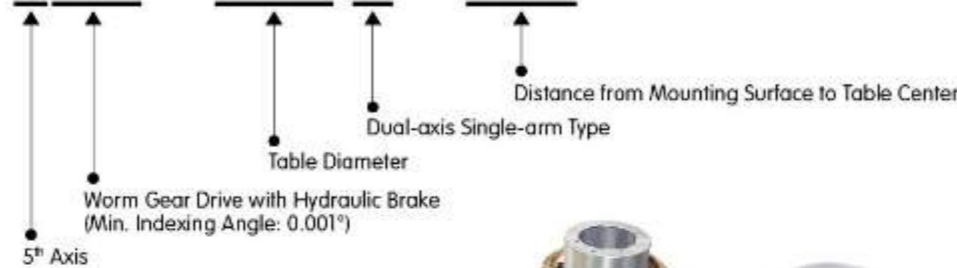

Drive by  
Worm & Worm Gear



Use  
radial & axial bearings



Wrap-around Brake



Item / Model	Unit	FHR-400S		FHR-650S-525 / 550	
Table Diameter	mm	Ø400		Ø650	
Inner Diameter of Mandrel Sleeve	mm	Ø120H7		-	
Diameter of Center Through Hole	mm	Ø105		-	
Table Height (Horizontal)	mm	-		-	
Table T-slot Width	mm	14H7		18H7	
Guide Block Width	mm	-		-	
Min. Increment	deg.	0.001		0.001	
Axis	-	Rotation	Tilt ±110°	Rotation	Tilt ±110°
Indexing Precision	sec.	15	60	15	60
Repeatability	sec.	6	8	6	8
Clamping System : Hydraulic	MPa (kgf/cm <sup>2</sup> )	3.5 (35)	3.5 (35)	3.5 (35)	3.5 (35)
Clamping torque (※1)	N·m (kgf·m)	1128 (115)	1962 (200)	3630 (370)	4905 (500)
Servo Motor Type	FANUC	Straight shaft without key	αiS12	αiF22	αiF40
	MITSUBISHI	Straight shaft without key	HG - 154	HG - 354	HG - 204
Speed Reduction Ratio	-	1 / 120	1 / 150	1 / 120	1 / 150
Max. Rotation Rate of Table (※2)	min <sup>-1</sup>	25	13.3	25	13.3
Allowable Inertia Load Capacity (Horizontal)	kg·m <sup>2</sup>	4.4		15.8	
Allowable Workpiece Load	0° Horizontal	kg	220	500	
	0°~90° Tilt	kg	120	300	
Allowable Thrust Load (with Rotary Table Clamping)	F	N (kgf)	17658 (1800)	17658 (1800)	
	FxL	N·m (kgf·m)	1962 (200)	4905 (500)	
	FyL	N·m (kgf·m)	1128 (115)	3630 (370)	
	FzL	N·m (kgf·m)	785 (80)	2453 (250)	
Driving Torque	N·m (kgf·m)	785 (80)		2453 (250)	
Net Weight (without motor)	kg	482		1120	

※1 : If a mechanical brake is not used, this value will correspond to the motor's holding torque.  
 ※2 : The structural limit value, while the actual operating speed will vary depending on the motor.

## FHR-400S

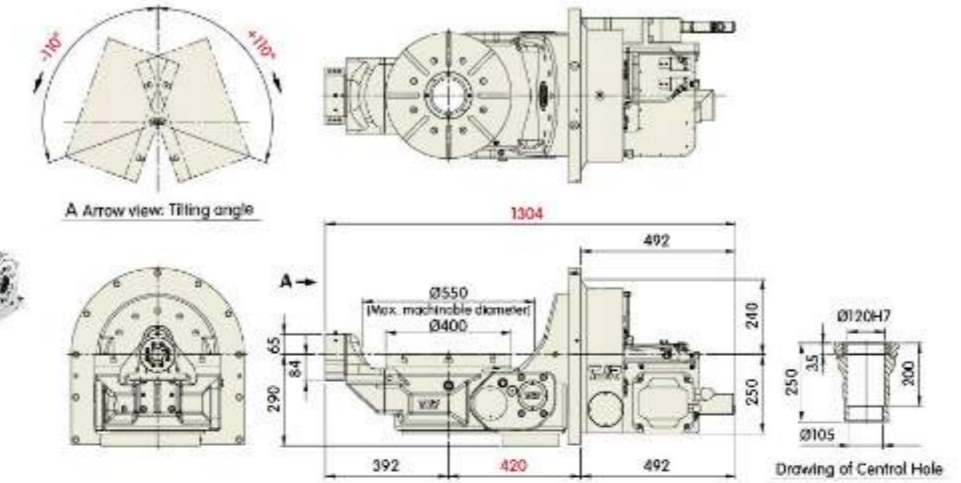

## FHR-650S-525

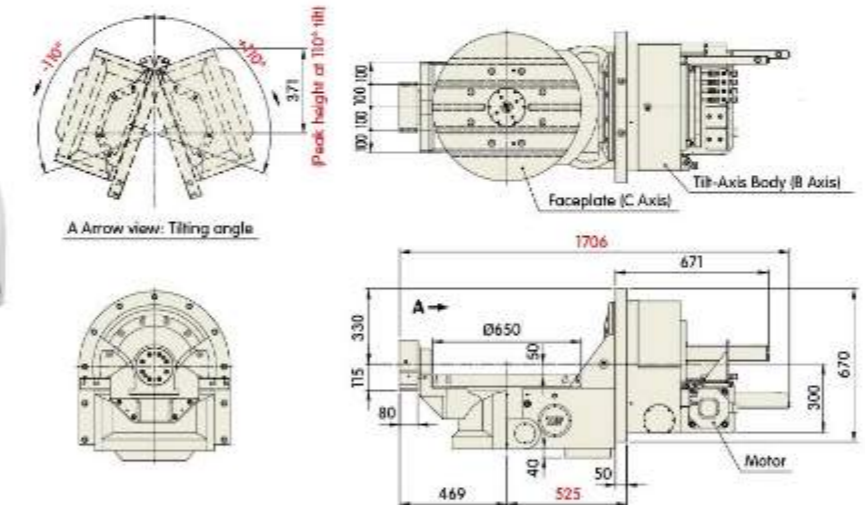

## FHR-650S-550

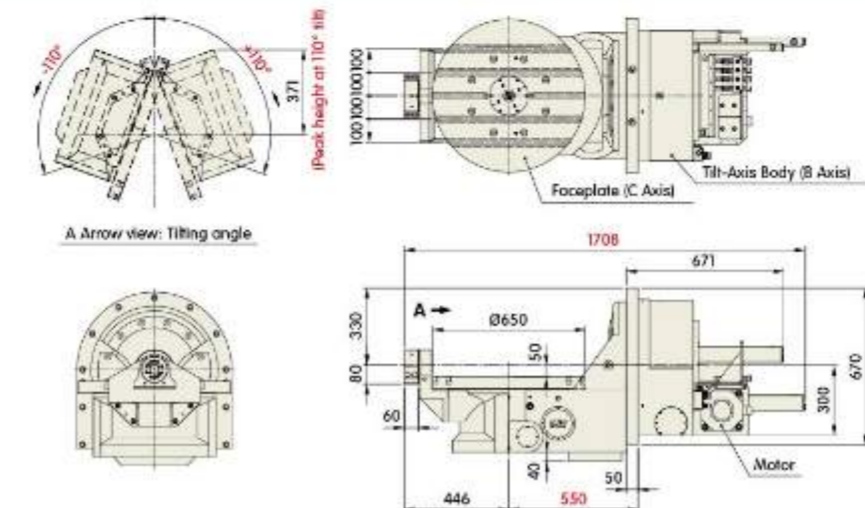

## CHI Series (for HMC use)



- CHI Series:**  
**Three-Piece Clutch Plate Design Advantages:**
- ① Positioning accuracy up to  $\pm 5$  arcseconds. (comparable to angle encoder precision)
  - ② Table surface remains flat during rotation, preventing chips or coolant from entering.

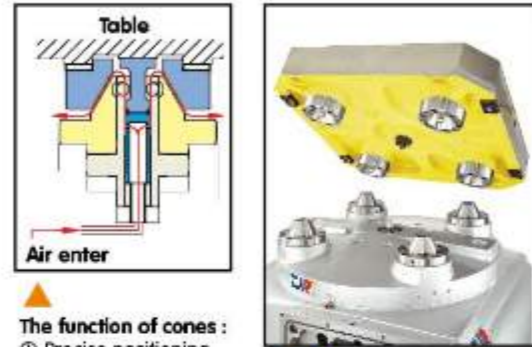

- The function of cones:**
- ① Precise positioning
  - ② Air blast for chip removal
  - ③ Airtight testing

**Cones:**  
Powerful hydraulic clamping

### CHI-400 (1° or 5°)



### CHI - 400

Table Size  
 Hirth Coupling Index Table with Hydraulic Brake  
 (Min. Indexing Angle: 1° or 5°)  
 Dual-pallet HI/HR series for APC



Item / Model	Unit	CHI-400	
Table Size	mm	□400x400	
Diameter of Table Central Hole	mm	∅50x27 deep	
Table Height	mm	410	
Table T-slot Width	mm	14H7	
Guide Block Width	mm	18h7	
Min. Increment	deg.	1° or 5°	
Indexing Precision	sec.	±5	
Repeatability	sec.	±1	
Clamping Force of Positioning Cones	N (kgf)	9418x4=37672 (960x4=3840)	
Clamping System : Hydraulic	MPa (kgf/cm <sup>2</sup> )	3.5(35)	
Clamping Torque	N·m (kgf·m)	4905 (500)	
Servo Motor Type	FANUC	Straight shaft without key	αiF12 / βis22
	MITSUBISHI	Straight shaft without key	HG / HF - 204
Speed Reduction Ratio	-	1 / 120	
Max. Rotation Rate of Table	r.p.m	25	
Allowable Workpiece Load	Horizontal	kg	400
Driving Torque	N·m (kgf·m)	-	
Net Weight (without motor)	kg	410	

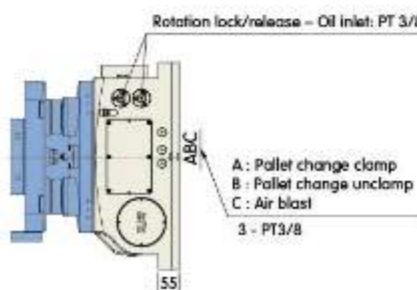
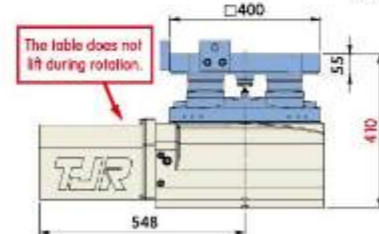
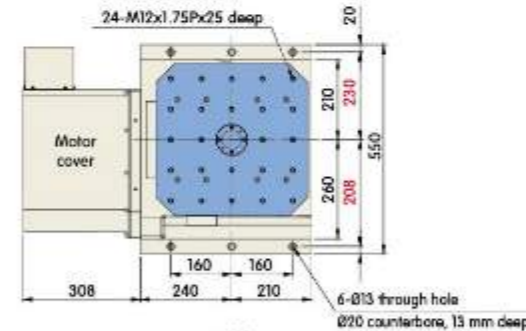

## CTH Series (for HMC use)

### CTH-400

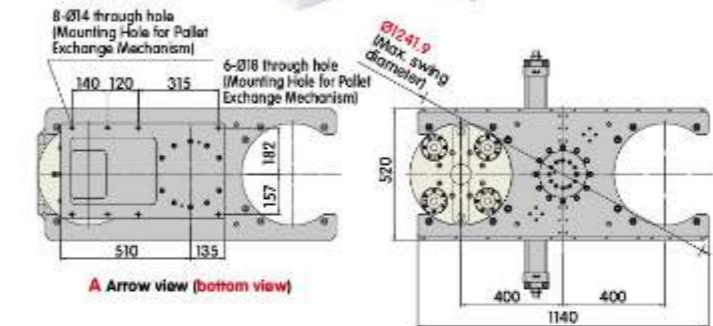

### CTH - 400

Tray type APC (180° to and fro)  
 Compatible Model Table Size



Item / Model	Unit	CTH-400	
Lifting Mechanism	-	Tray type (H type)	
Pallet Size	mm	520x1140	
Rotation Method	-	Hydraulic hirth coupling	
Rotation Angle	deg.	180° to and fro	
Clamping System (Hydraulic)	MPa (kgf/cm <sup>2</sup> )	3.5(35)	
Positioning Method	-	Cone positioning	
Clamping Force	N (kgf)	9418x4=37672 (960x4=3840)	
Operating System (Up & Down & Rotate) (Hydraulic)	MPa (kgf/cm <sup>2</sup> )	3.5(35)	
Lifting Thrust Force	N (kgf)	21582 (2200)	
Up and Down Travel of the Pallet	mm	60	
Allowable Workpiece Load	Horizontal	kg	400x2=800
<b>Inspection Precision</b>			
Repeatability accuracy on positioning of the same pallet	mm	0.01	
Max. positioning tolerance for 2 pallets	mm	0.02	
Parallelism of pallet top and base bottom	mm	0.02	

### CTH-400+CHI-400

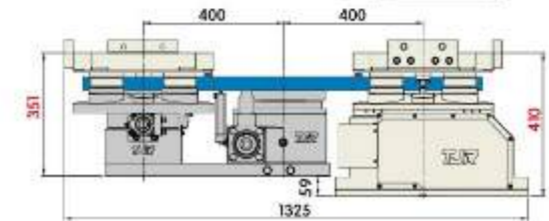
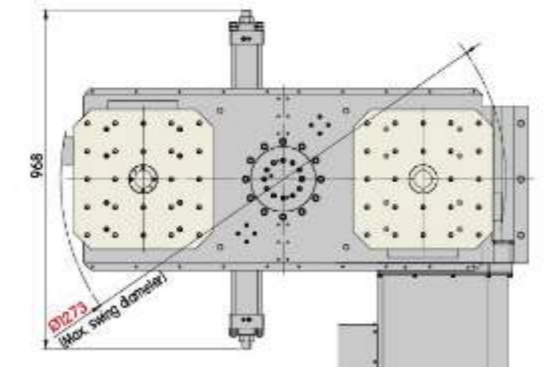

Driven by Worm & Worm Gear

Driven by Worm & Worm Gear

## CHI/CHR Series (for HMC use)

## CTH Series (for HMC use)



**CHI Series:**  
**Three-Piece Clutch Plate**  
**Design Advantages:**  
 ① Positioning accuracy up to  $\pm 5$  arcseconds. (comparable to angle encoder precision)  
 ② Table surface remains flat during rotation, preventing chips or coolant from entering.

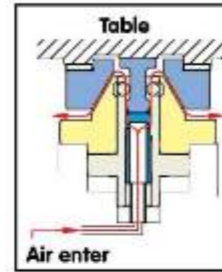

**The function of cones:**  
 ① Precise positioning  
 ② Air blast for chip removal  
 ③ Airtight testing

**Cones:**  
 Powerful hydraulic clamping



CHI-500



CHR-500

### CHI-500 (1° or 5°)

### CHI - 500

Table Size  
 HI Hirth Coupling Index Table with Hydraulic Brake (Min. Indexing Angle: 1° or 5°)  
 HR Worm Gear Drive with Hydraulic Brake (Min. Indexing Angle: 0.001°)  
 Dual-pallet HI/HR series for APC

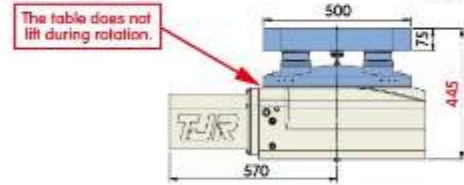
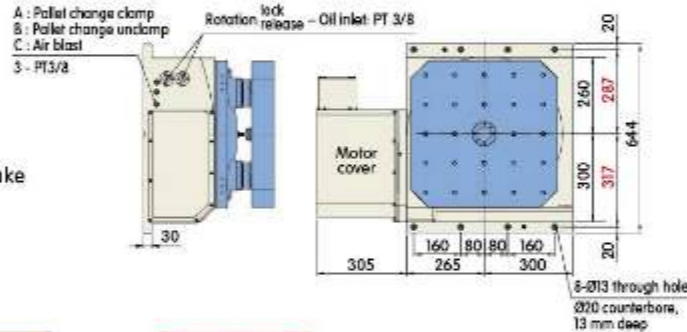

### CHR-500 (0.001°)

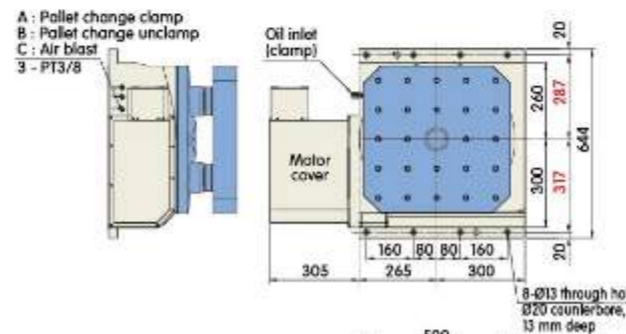

The motor cover can be modified as the interface of telescopic cover.

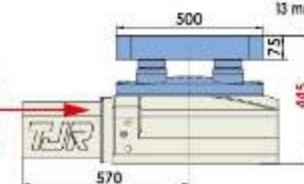

### CTH-500

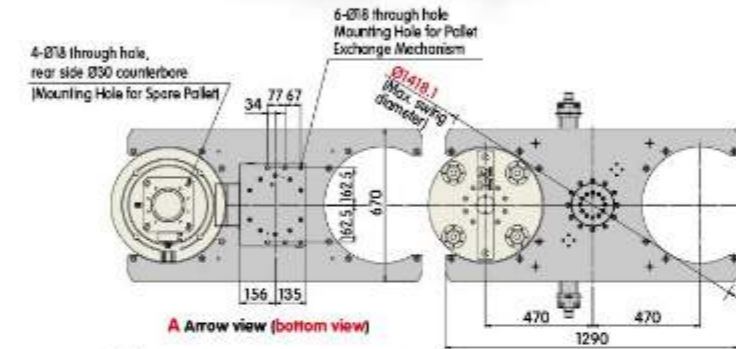

### CTH - 500

Tray type APC (180° to and fro)  
 Compatible Model Table Size

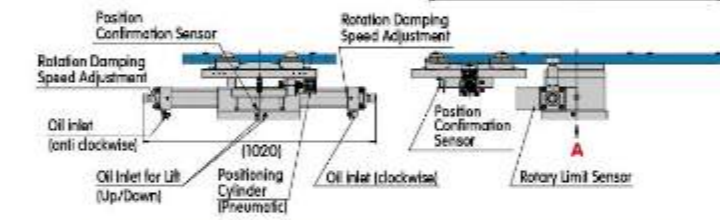

### CTH-500+CHI-500

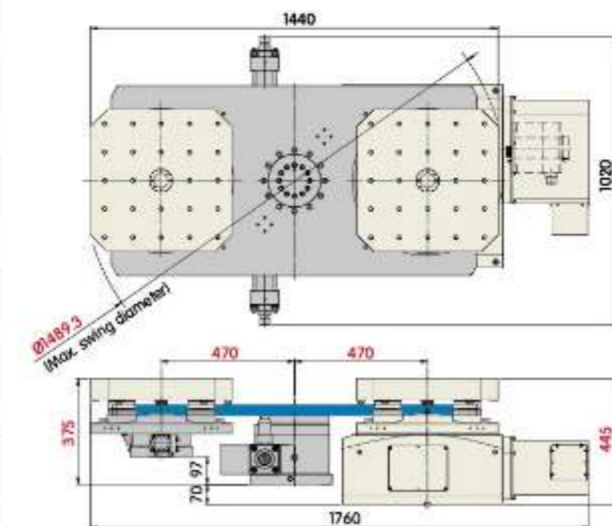

Item / Model	Unit	CTH-500
Lifting Mechanism	-	Tray type (H type)
Pallet Size	mm	670x1290
Rotation Method	-	Hydraulic hirth coupling
Rotation Angle	deg.	180° to and fro
Clamping System (Hydraulic)	MPa (kgf/cm <sup>2</sup> )	3.5(35)
Positioning Method	-	Cone positioning
Clamping Force	N (kgf)	9418x4=37672 (960x4=3840)
Operating System (Up & Down & Rotate) (Hydraulic)	MPa (kgf/cm <sup>2</sup> )	4.5(45)
Lifting Thrust Force	N (kgf)	28057 (2860)
Up and Down Travel of the Pallet	mm	60
Allowable Workpiece Load	Horizontal	kg
Inspection Precision		
Repeatability accuracy on positioning of the same pallet	mm	0.01
Max. positioning tolerance for 2 pallets	mm	0.02
Parallelism of pallet top and base bottom	mm	0.02

Driven by Worm & Worm Gear

Driven by Worm & Worm Gear



## CTU Series (for HMC use)

### CTU-400x600

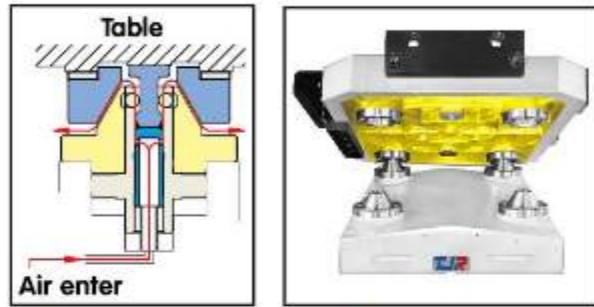

- ▲ The function of cones :**
- ① Precise positioning
  - ② Air blast for chip removal
  - ③ Airtight testing
- ▲ Cones:** Powerful hydraulic clamping

### CTU - 400x600

Hook type auto pallet changer  
(180° to and fro)



Item / Model	Unit	CTU-400x600	CTU-500x700
Lifting Mechanism	-	Hook type (U type)	Hook type (U type)
Table Size	mm	□400x600	□500x700
Rotation Method	-	Hydraulic hirth coupling	Hydraulic hirth coupling
Rotation Angle	deg.	180° to and fro	180° to and fro
Clamping System (Hydraulic)	MPa (kgf/cm <sup>2</sup> )	3.5(35)	3.5(35)
Positioning Method	-	Cone positioning	Cone positioning
Clamping Force of Positioning Cones (35kg/cm <sup>2</sup> )	N (kgf)	9418x4=37672 (960x4=3840)	9418x4=37672 (960x4=3840)
Operating System (Up & Down & Rotate)	MPa (kgf/cm <sup>2</sup> )	4.5(45) Hyd.	4.5(45) Hyd.
Lifting Thrust Force	N (kgf)	28057 (2860)	28057 (2860)
Up and Down Travel of the Pallet	mm	60	60
Allowable Workpiece Load	Horizontal	kg	250x2=500
<b>Inspection Precision</b>			
Repeatability accuracy on positioning of the same pallet	mm	0.01	
Max. positioning tolerance for 2 pallets	mm	0.02	
Parallelism of pallet top and base bottom	mm	0.02	

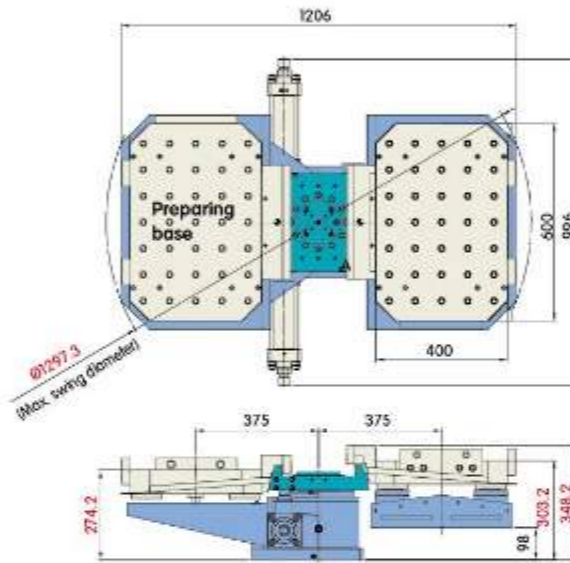

### CTU-500x700

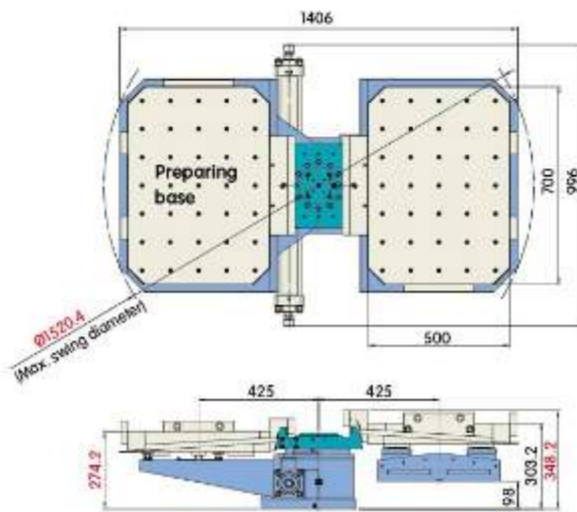

## CURC Series (for C-Type VMCs and Drilling/Tapping Centers)



### CURC - 500x700

CNC Hook-Type Roller Gear Cam Drive  
(180° to and fro)



Item / Model	Unit	CURC-500x700	
Lifting Mechanism	-	Hook type (U type)	
Table Size	mm	500 x 700	
Rotation Method	-	Servo motor	
Rotation Angle	deg.	180° to and fro	
Clamping System (Hydraulic)	MPa (kgf/cm <sup>2</sup> )	3.5(35)	
Positioning Method	-	Cone positioning	
Clamping Force (35kg/cm <sup>2</sup> )	N (kgf)	9418x4=37672 (960x4=3840)	
Operating System (Up & Down & Rotate)	MPa (kgf/cm <sup>2</sup> )	3.5(35) Hyd.	
Lifting Thrust Force	N (kgf)	21582 (2200)	
Up and Down Travel of the Pallet	mm	60	
Servo Motor Type	FANUC	Straight shaft βis12	
	DELTA	Straight shaft ECMA-E 1320GS	
	mitsubishi	Straight shaft HG - 224	
Speed Reduction Ratio	-	1 / 90	
Allowable Workpiece Load	Horizontal	kg	250x2=500
<b>Inspection Precision</b>			
Repeatability accuracy on positioning of the same pallet	mm	0.01	
Max. positioning tolerance for 2 pallets	mm	0.02	
Parallelism of pallet top and base bottom	mm	0.02	
Saddle + Single Table Weight (Excluding Motor)	kg	712	

### CURC-500x700

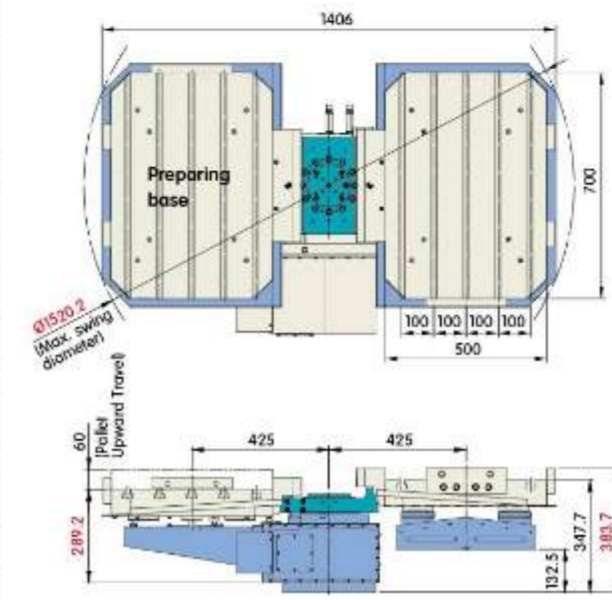

Driven by Roller Gear Cam



## Direct Drive (5<sup>th</sup> Axis) Series

### FAD - 170 F - AD261 iB - FA

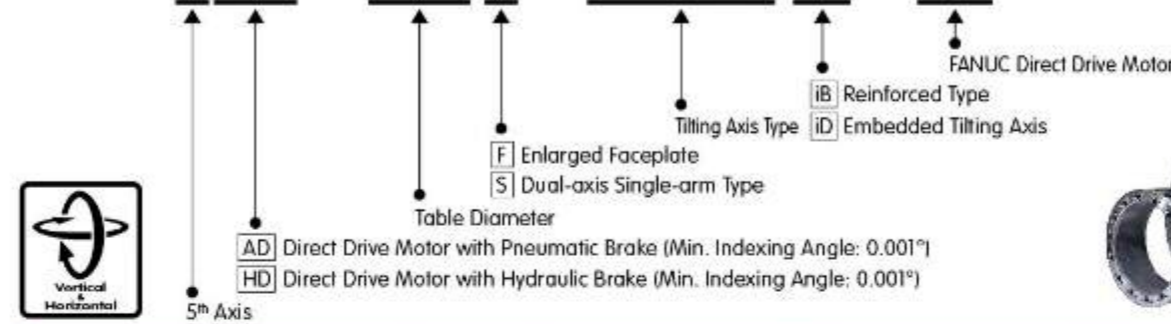

Item / Model	Unit	FAD-170F / 210F		FAD-211-AD261iB-FA		FHD-650S-iD650	
Table Diameter	mm	Ø170 / Ø210		Ø210		Ø650	
Inner Diameter of Mandrel Sleeve	mm	Ø40H7		Ø40H7		-	
Diameter of Center Through Hole	mm	Ø40		Ø40		-	
Center Height (Horizontal)	mm	250		310		-	
Table T-slot width	mm	12H7		12H7		18H7	
Guide block width	mm	18h7		18h7		-	
Axis	-	Rotation	Tilt ±100°	Rotation	Tilt ±100°	Rotation	Tilt ±110°
Transmission Mechanisms	-	Direct Drive	Direct Drive	Direct Drive	Direct Drive	Direct Drive	Direct Drive
Cooling System	-	Free Cooling	Free Cooling (Oil Cooling)	Free Cooling	Free Cooling (Oil Cooling)	Oil Cooling	Oil Cooling
Min. increment	deg.	0.001	0.001	0.001	0.001	0.001	0.001
Indexing Precision (A axis 0°~+90°)	sec.	20	30	20	30	20 (※1)	30 (※1)
Repeatability	sec.	4	4	4	4	4	4
Clamping System : Pneumatic / Hydraulic	MPa	0.6 (Pne.)	0.6 (Pne.)	0.6 (Pne.)	0.6 (Pne.)	3.5 (Hyd.)	3.5 (Hyd.)
Clamping Torque	Nm	310	450	310	450	3700	5000
Servo Motor Type	-	DD Motor	DD Motor	FANUC DIS DD Motor	FANUC DIS DD Motor	DD Motor	DD Motor
Speed Reduction Ratio	-	Direct Drive	Direct Drive	Direct Drive	Direct Drive	Direct Drive	Direct Drive
Rated / Max. Speed	r.p.m	200 / 300	50 / 150	200 / 300	150 / -	80 / 210	50 / 50
Rated / Max. Cutting Torque	Nm	29 / 87	48 (Cooling) / 143	40 (Cooling) / 80 / 200	57 (Cooling) / 120 / 300	554 / 741	1890 / 2478
Allowable Inertia Load Capacity (0° Horizontal)	kg·m <sup>2</sup>	1.08		1.65		26.4	
Allowable workpiece load	0° Horizontal	kg		50		50 (Rated Speed)	
	0°~90° Tilt	kg		30		30 (Rated Speed)	
Allowable Thrust Load (with Rotary Table Clamping)	F	N		4000		4000	
	FxL	Nm		450		450	
	FyL	Nm		310		310	
Net Weight (D.D motor included)	kg	220 (Ø170) / 223 (Ø210)		237		1173	
<b>Electrical Specification</b>							
Encoder	-	RENISHAW or HEIDENHAIN		FANUC aiCZ Encoder		HEIDENHAIN	
Back EMF Voltage	Vrms/100rpm	Rotation : 38.8		-		125.6	
Rotor Poles	-	44		28 [Rotation] 28 [Tilt]		66	
Rated / Max. Current	Arms	4.25 / 12.75		10.2 / 28.3 [Rotation] 19.5 / 53.2 [Rotation]		29.8 / 75.7 (Oil Cooling)	
Power Rating	KW	0.77 0.76		-		4.7 10.1	

※1 : To further enhance positioning accuracy, higher-grade angle encoders are available as an upgrade. Please refer to page P78 for applicable specifications and corresponding accuracy.

### FAD-170F / 210F (Taiwan-made DDM)

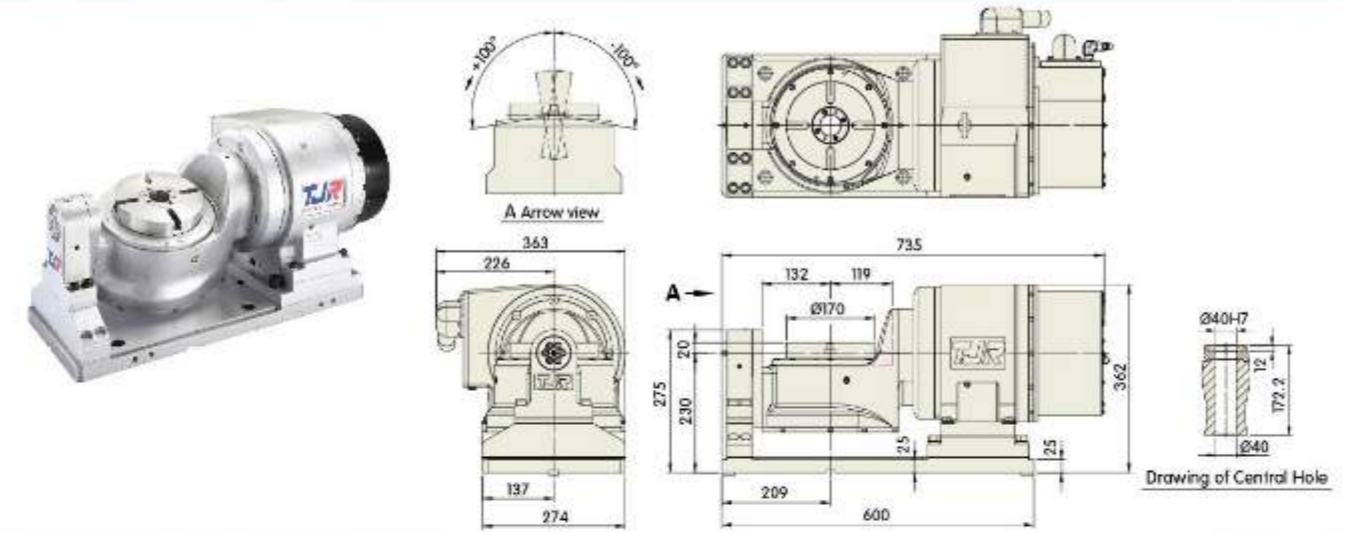

### FAD-211-AD261iB-FA (FANUC OEM DDM)

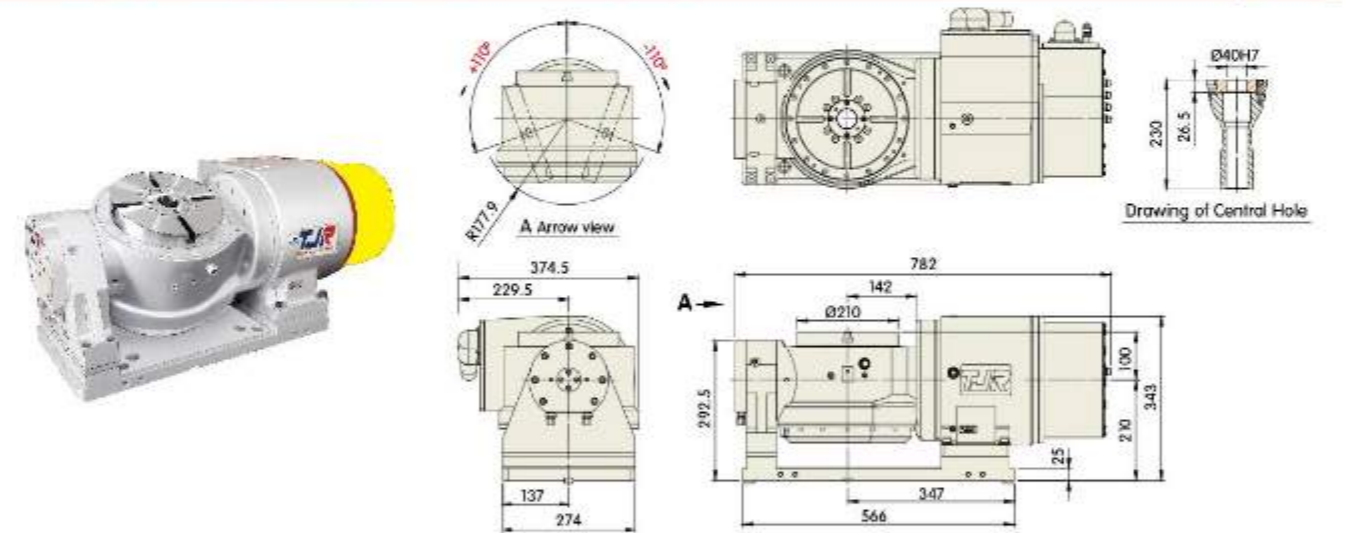

### FHD-650S-iD650 (FANUC OEM DDM & Taiwan-made DDM)

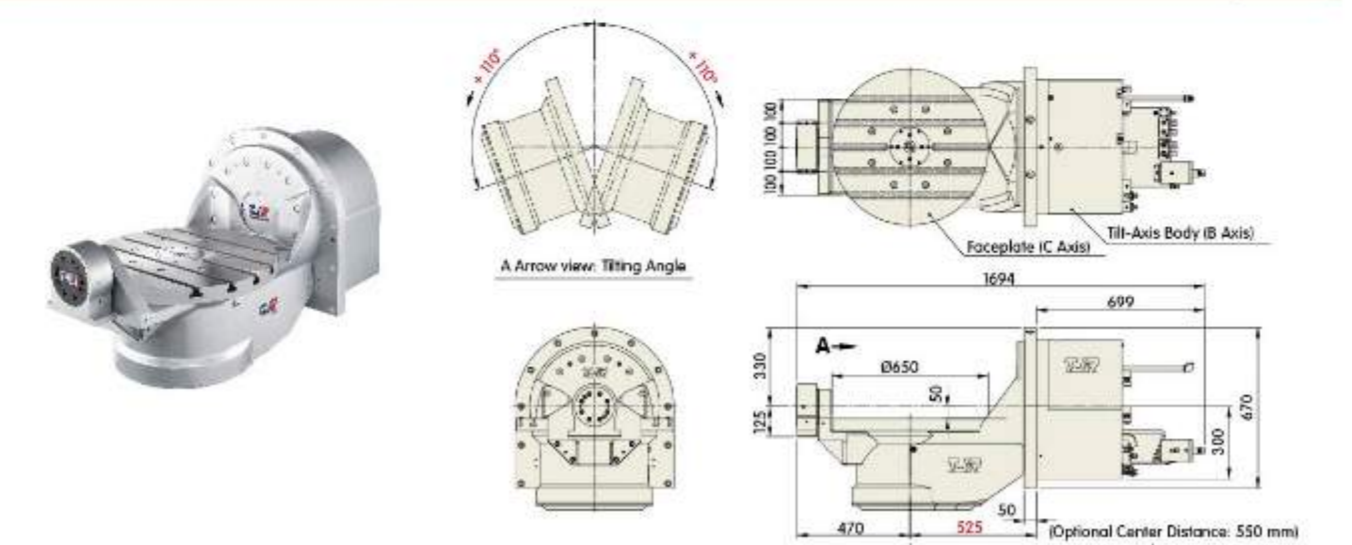

Driven by Direct Drive Motor

## Direct Drive (5<sup>th</sup> Axis) Series

### FAD - 300 F - HS - iD500 - 480

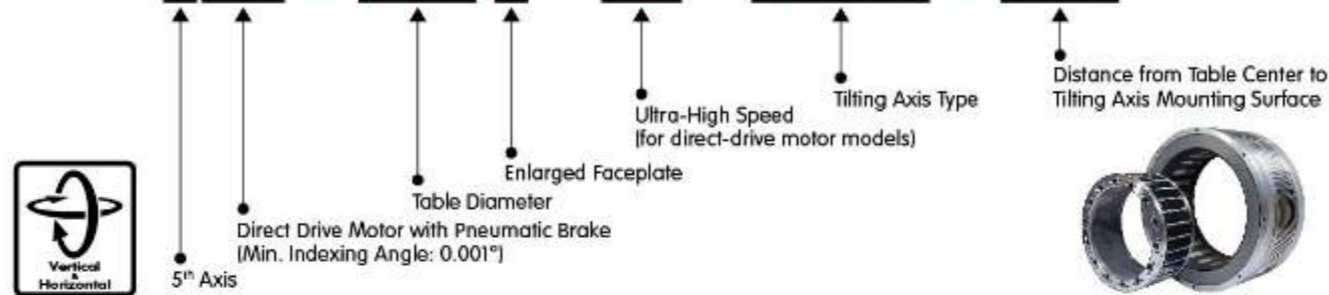

Item / Model	Unit	FAD-300F-HS		FAD-400HS-AD500i-420 / FAD-500FHS-AD500i-480	
Table Diameter	mm	Ø300		Ø400 / Ø500	
Inner Diameter of Mandrel Sleeve	mm	Ø25H7 x 12 deep (Diameter of table central hole)		Ø25H7 x 12 deep (Diameter of table central hole)	
Diameter of Center Through Hole	mm	-		-	
Center Height (Vertical)	mm	-		-	
Table Height (Horizontal)	mm	385		-	
Table T-slot width	mm	14H7		14H7	
Guide block width	mm	14h7		-	
Axis	-	Rotation	Tilt ±120°	Rotation	Tilt ±110°
Cooling System	-	Chilled Water Cooling	Chilled Water Cooling	Chilled Water Cooling	Chilled Water Cooling
Transmission Mechanisms	-	Direct Drive	Direct Drive	Direct Drive	Direct Drive
Min. increment	deg.	0.001	0.001	0.001	0.001
Indexing Precision (A axis 0°~+90°)	sec.	20	30	20	25
Repeatability	sec.	4	4	4	4
Clamping System : Pneumatic	MPa	0.6	0.6	0.6	0.6
Clamping Torque	Nm	430	730	850	2000
Servo Motor Type	-	DD Motor	DD Motor	DD Motor	DD Motor
Speed Reduction Ratio	-	Direct Drive	Direct Drive	Direct Drive	Direct Drive
Rated / Max. Speed	r.p.m	818 / 2000 (600VDC)	50 / 50	596 / 1200 (Ø400) or 596 / 800 (Ø500)	50 / 50
Rated / Max. Cutting Torque	Nm	113 / -	554 / 741	402 / -	1217 / 2120
Allowable Inertia Load Capacity (0° Horizontal)	kg-m <sup>2</sup>	1.2		4.0	
Allowable workpiece load	0° Horizontal	kg	100 (Rated Speed)	200 (balanced load)	
	0°~90° Tilt	kg	100 (Rated Speed)	100 (balanced load)	
Allowable Thrust Load (with Rotary Table Clamping)	F	N	-	15000	
	FxL	Nm	730	2000	
	FxL	Nm	430	850	
Net Weight (D.D motor included)	kg	730		882 (Ø400) / 914 (Ø500)	
<b>Electrical Specification</b>					
Encoder	-	RENISHAW or HEIDENHAIN		RENISHAW or HEIDENHAIN	
Back EMF Voltage	Vrms/100rpm	Rotation : 33		Rotation : 45.55	
Rotor Poles	-	22		44	
Rated / Max. Current	Arms	26.5 / 50.2		Rotation : 66.9 / 151	
Power Rating	KW	9.9	4.7	25.6	6.5

### FAD-300F-HS (Taiwan-made DDM)



Equipped with a built-in pneumatic rotary joint (2 port)

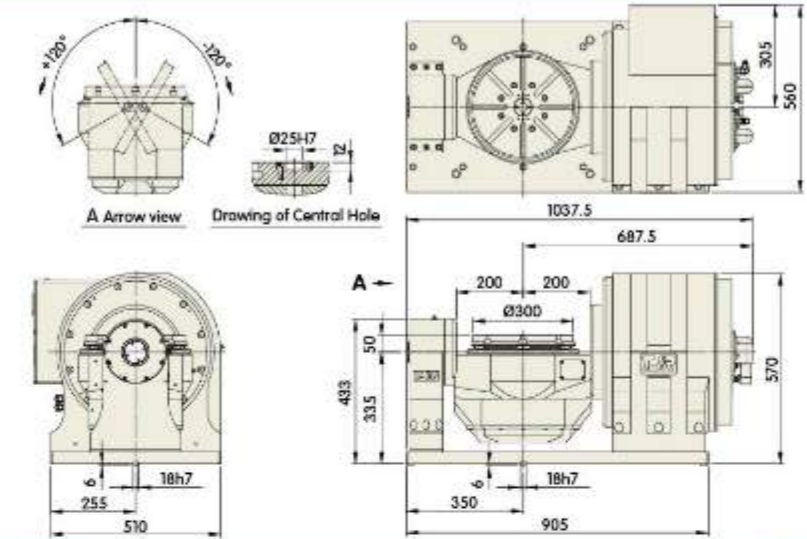

### FAD-400HS-AD500i-420 (Taiwan-made DDM)



Equipped with a built-in pneumatic rotary joint (4 port)

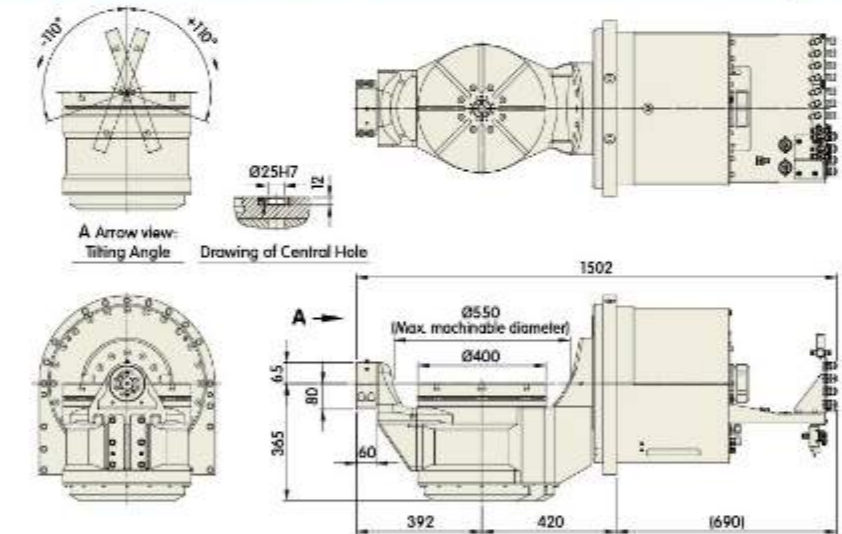

### FAD-500FHS-AD500i-480 (Taiwan-made DDM)



Equipped with a built-in pneumatic rotary joint (4 port)

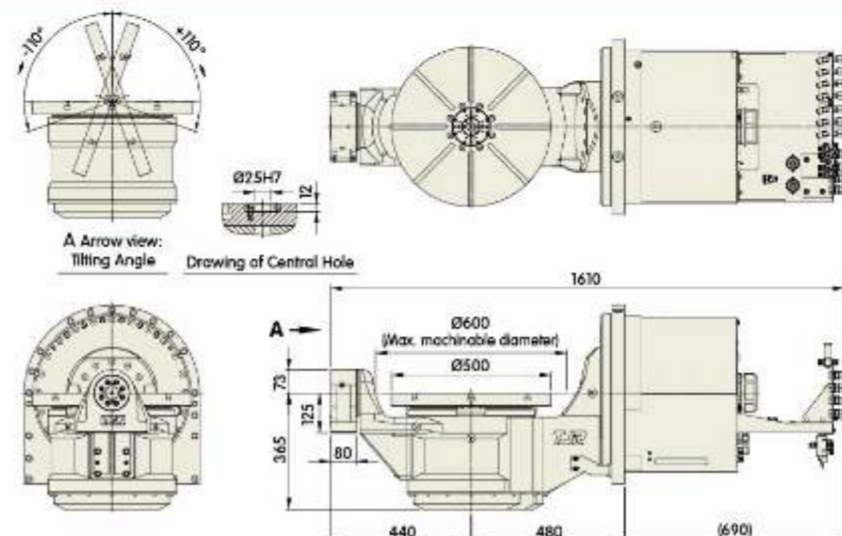

## Support Table

Item / Model	Unit	RT-135	RT-170F	RTA-125	RTA-170 RTA-170H	RTA-210 / 250 RTA-210H / 250H	RTH-255	RTH-320	RTH-400A	RTH-400
Table Diameter	mm	Ø100	Ø170	Ø125	Ø170	Ø210 / Ø250	Ø255	Ø320	Ø400	Ø400
Inner Diameter of Mandrel Sieve	mm	Ø35H7	Ø40H7	Ø35H7	Ø40H7	Ø40H7	Ø80H7	Ø120H7	Ø120H7	Ø120H7
Diameter of Center Through Hole	mm	Ø25	Ø40	Ø25	Ø40	Ø40	Ø80	Ø80	Ø80	Ø80
Center Height (Vertical)	mm	135	135	110	135	160	160	210	255	255
Table T-slot Width	mm	-	12H7	12H7	12H7	12H7	12H7	14H7	14H7	14H7
Guide block Width	mm	14h7	18h7	14h7	18h7	18h7	18h7	18h7	18h7	18h7
Clamping System : Pne. 0.6(6) / Hyd. 3.5(35)	MPa (kgf/cm <sup>2</sup> )	-	-	Pne.	Pne. RTA-170 Hyd. RTA-170H	Pne. RTA-210 / 250 Hyd. RTA-210H / 250H	Hyd.	Hyd.	Hyd.	Hyd.
Clamping torque	N-m (kgf-m)	-	-	128 (13)	304 (31) 540 (55)	304 (31) 540 (55)	687 (70)	1128 (115)	1128 (115)	1962 (200)
Allowable Workpiece Load	kg	50	50	50	75	75	100	150	150	250
Tailstock Total Weight	kg			18	29	35 / 38	57	83	106	164

**RTH-255 (Hydraulic 70 kgf-m)**

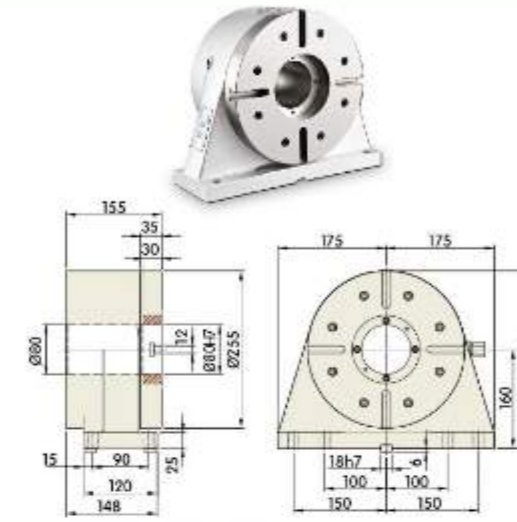

**RTH-320 (Hydraulic 115 kgf-m)**

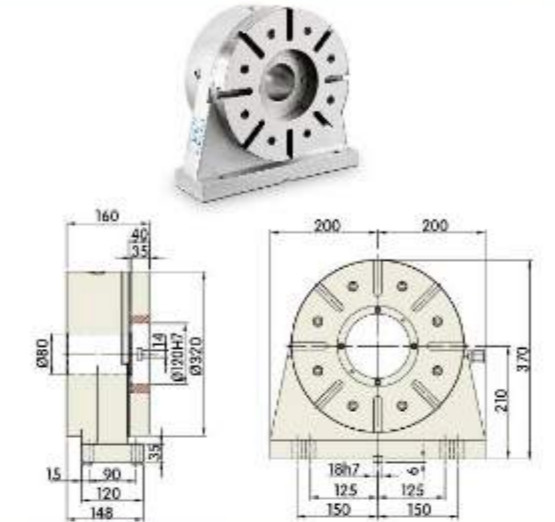

**RTA-125 (Pneumatic 13 kgf-m)**

### RTA - 170 H

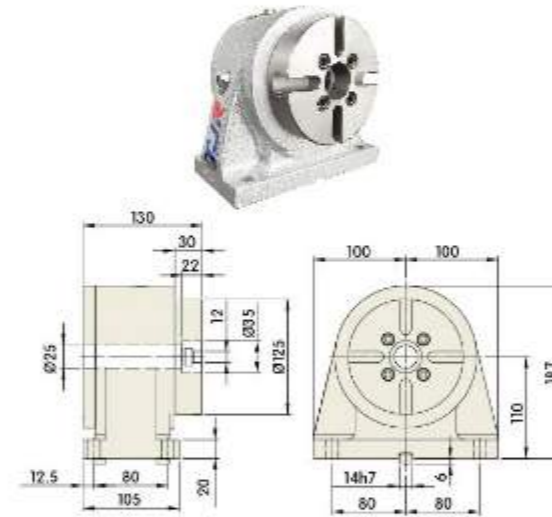
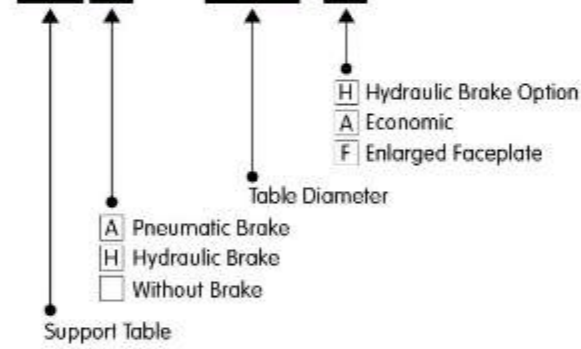

**RTH-400 (Hydraulic)**

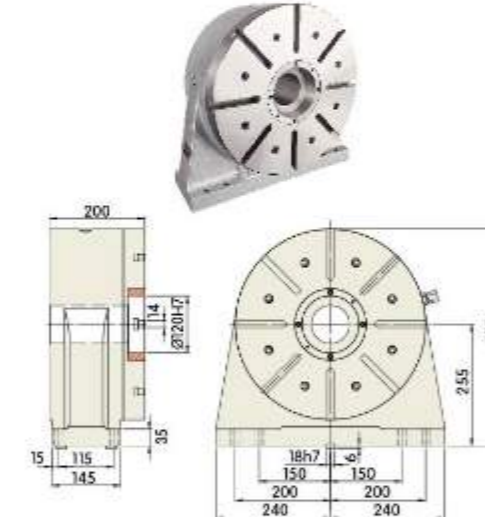

**RTH-400A (Hydraulic 115 kgf-m)**

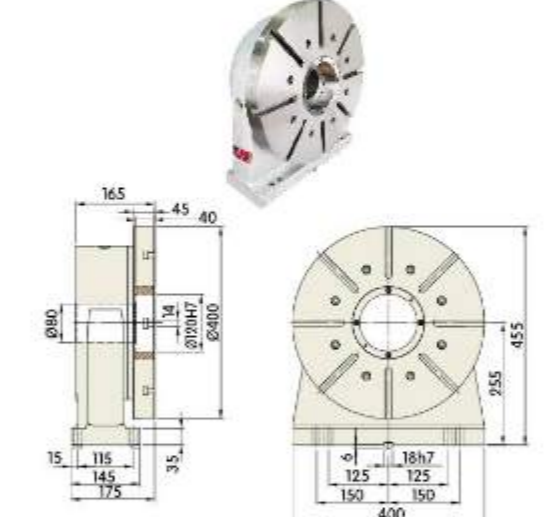

**RTA-170 (Pneumatic 31 kgf-m)**  
**RTA-170H (Hydraulic 55 kgf-m)**

**RTA-210 / 250 (Pneumatic 31 kgf-m)**  
**RTA-210H / 250H (Hydraulic 55 kgf-m)**

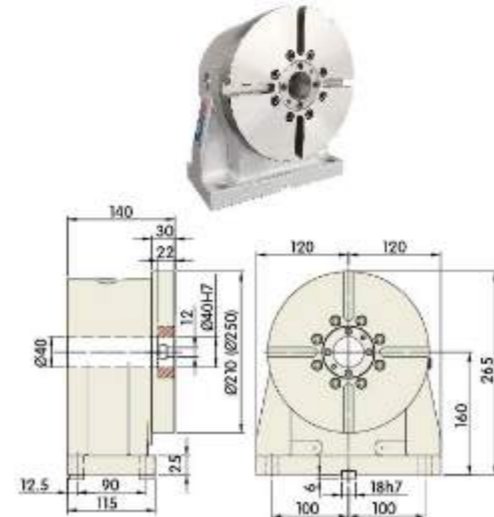
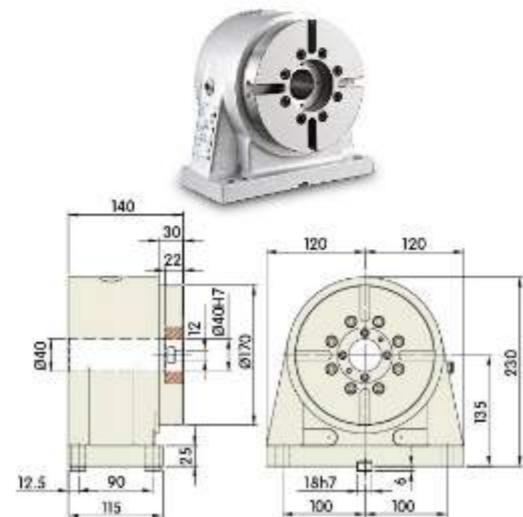

**RT-170F (Without Brake)**

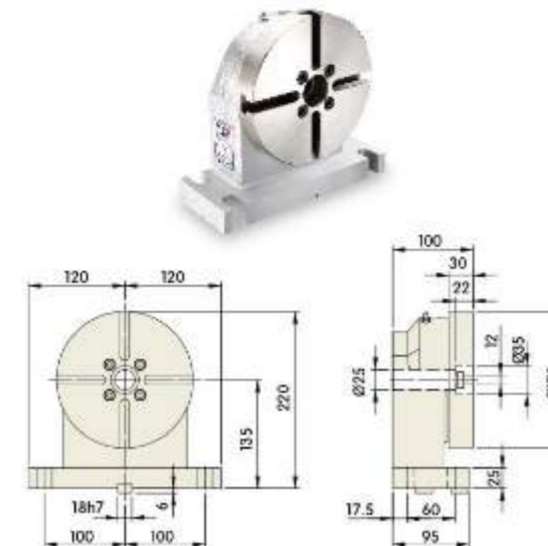

**RT-135 (Without Brake)**



## Manual Tailstock

TTJ Series (Manual) Unit : mm						
Model	A	B	C	D	Weight (kg)	Tailstock Center Specification
TTJ - 125A	110	155	14	312	8.5	MT2
TTJ - 125	110	156	14	435.5	21.5	MT4
TTJ - 170	135	181	18	435.5	23	MT4
TTJ - 210	160	206	18	435.5	25	MT4
TTJ - 255	160	206	18	435.5	25	MT4
TTJ - 320	210	256	18	435.5	29	MT4 / MT5
TTJ - 400	255	310	18	503.5	48	MT4 / MT5

### TTJ-125A (For light cutting) (Weight : 8.5 kg)

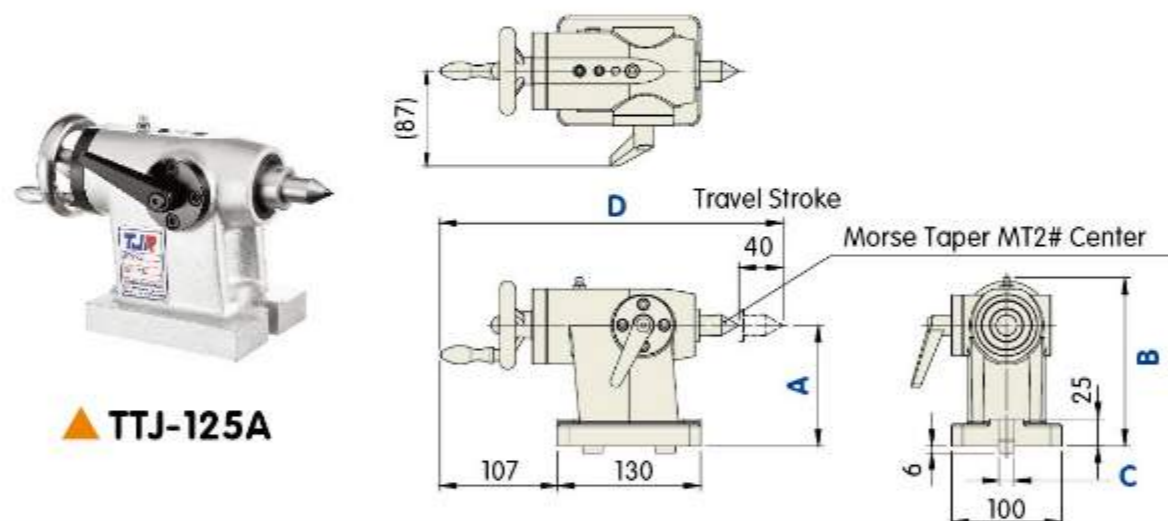

▲ TTJ-125A

### TTJ

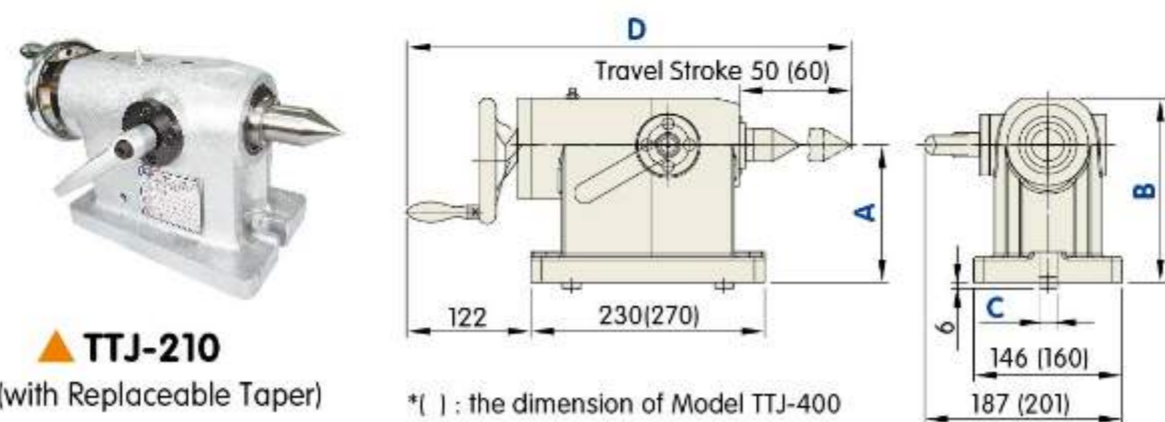

▲ TTJ-210  
(with Replaceable Taper)

\* ( ) : the dimension of Model TTJ-400

ATTJ Series (Pneumatic) / HTTJ Series (Hydraulic) Unit : mm						
Model	A	B	C	D	Weight (kg)	Tailstock Center Specification
ATTJ - 125	110	156	14	376	21	MT4
ATTJ - 170	135	181	18	376	23	MT4
ATTJ - 210	160	206	18	376	25	MT4
HTTJ - 210	160	206	18	376	25	MT4
HTTJ - 255	160	206	18	376	25	MT4
HTTJ - 320	210	256	18	376	29	MT4 / MT5
HTTJ - 400	255	310	18	495	50	MT4 / MT5

### ATTJ



▲ ATTJ-210  
(with Pneumatic switching valve)

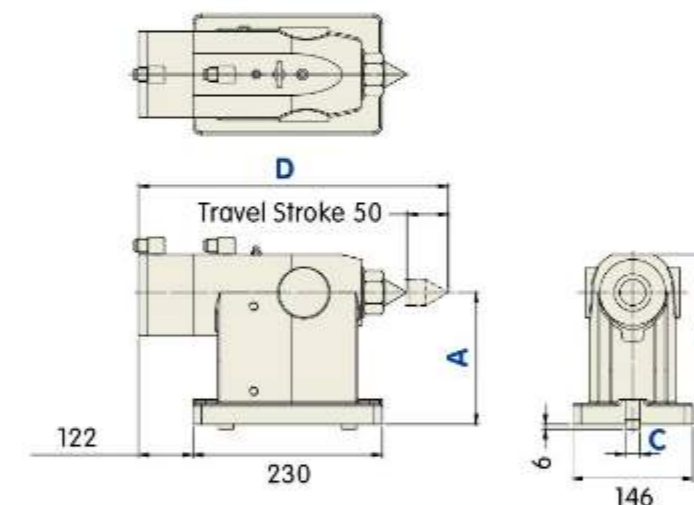

### HTTJ



▲ HTTJ-320  
(with Hydraulic switching valve)

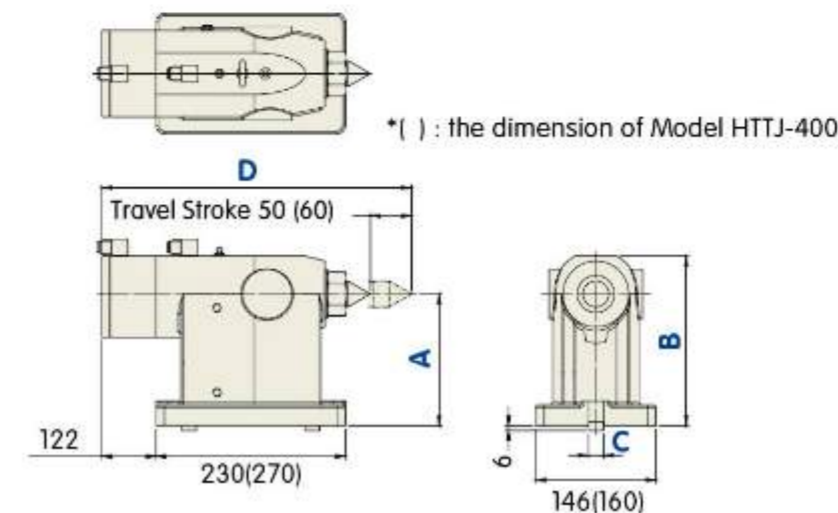

## CNC Rotary Table + Support Table + Connection Plates

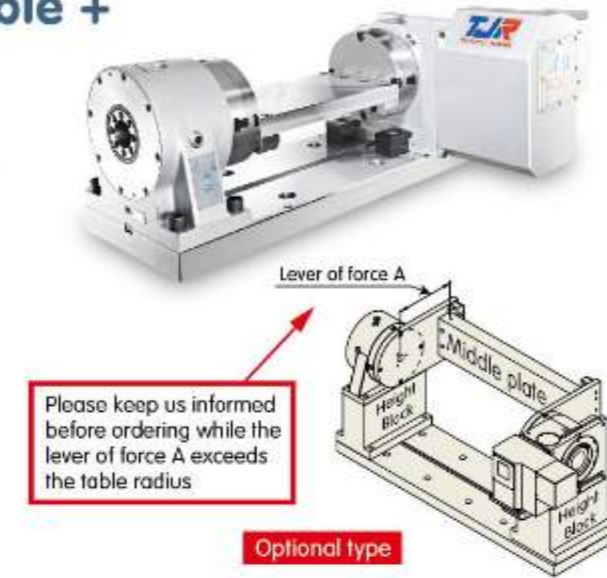
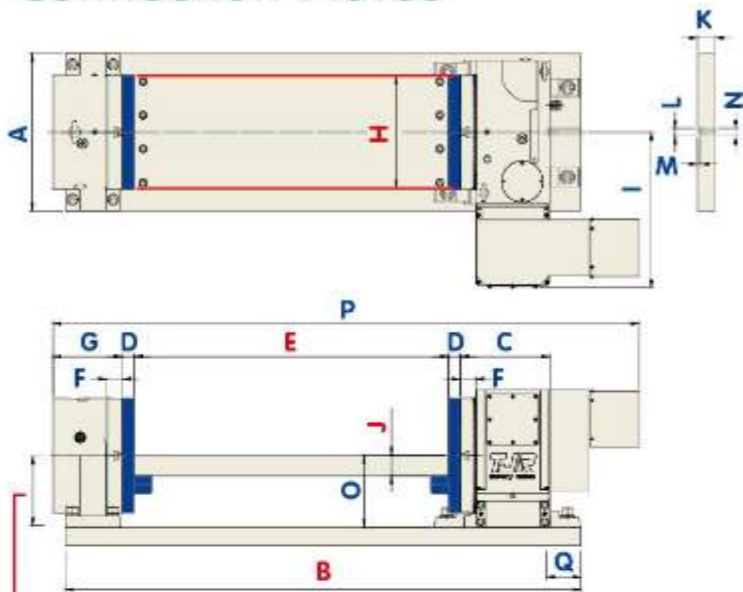

(Example of workpiece installation)

The plane of middle plate is at the same height as the center of rotary table (standard type)  
(An exception: the plane of ARs-125 / RTA-125 middle plate is 5 mm higher than the center of rotary table)

### Specification

Model / Dimension	A	B	C	D	E	F	G	H	I	J	K	L	M	N	O	P	Q
ARs-125 / RTA-125	250	725	152	20	400	30	130	125	302	30	35	14	8	14	110	828	0
AR-170(H) / RTA-170(H)	300	911	152	25	500	30	140	170	336	35	40	18	8	18	135	947	69
AR-210(H) / RTA-210(H)	300	1011	152	25	600	30	140	200	336	40	40	18	8	18	160	1047	69
AR-250(H) / RTA-250(H)	300	1020	160	25	600	38	140	250	336	40	40	18	8	18	160	1055	69
HR-255N / RTH-255	350	1148	200	25	700	35	155	250	346	45	40	18	8	18	160	1305	69
HR-320N / RTH-320	400	1297	235	30	800	40	160	300	416	45	40	18	8	18	210	1460	69
HR-400N / RTH-400A	450	1455	250	30	900	45	175	400	457	45	40	18	8	18	255	1572	69

※ J is the thickness of the middle plate, recommended for manufacturing.  
If the thickness is not enough, the middle plate will be easy to deform when twisted.

(Unit : mm)

### Disc L-block

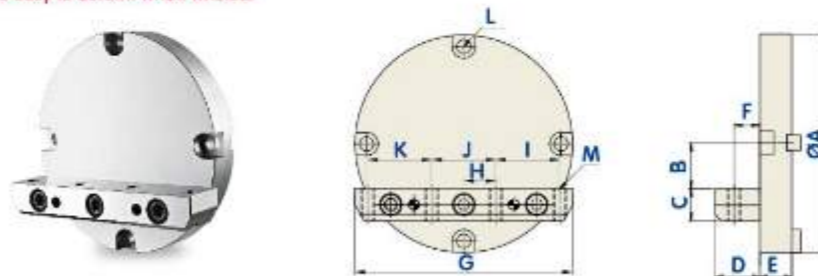

### Specification (Unit : mm)

Model / Dimension	ØA	B	C	D	E	F	G	H	I	J	K	L	M
ARs-125	Ø125	25	25	25	20	12.5	120	27	25	54	25	M10	4-M8
AR-170(H)	Ø170	35	25	35	25	20	170	25	50	50	50	M10	4-M10
AR-210(H)	Ø210	40	35	40	25	20	200	27.5	55	55	55	M10	4-M10
HR-255	Ø250	45	40	40	25	20	250	37.5	75	75	75	M10	4-M10
HR-320	Ø320	45	45	45	30	22.5	300	42.5	85	85	85	M12	4-M12
HR-400	Ø400	45	45	45	30	22.5	400	75	80	150	80	M12	4-M12

## Accessories Series

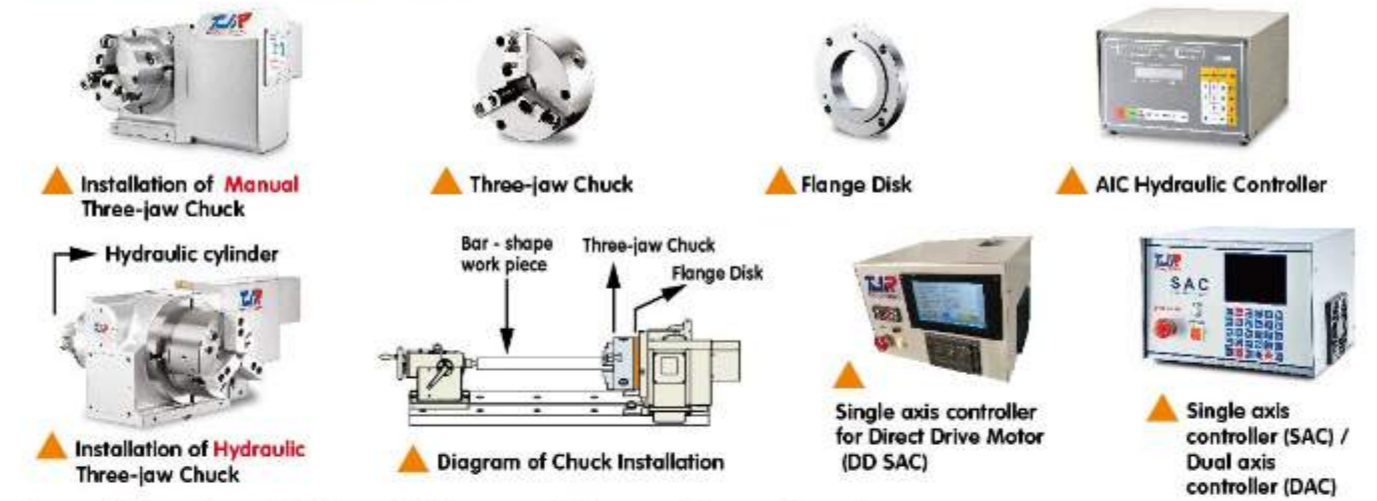

### Specification Table of Manual Three-jaw Chuck

Specification Sheet of Manual 3-Jaw Chuck (For Reference)						Max. Bar Through Hole Diameter (incl. Rotary Table & Chuck) (mm)	Chuck Adapter Plate Thickness (mm)
Applicable Rotary Table	Model & Dimension	I.D. Clamping Range (Standard Jaws)	O.D. Clamping Range (Reversed Jaws)	Manual Chuck Thickness (mm)	Chuck Through Hole Diameter (mm)		
ARs-125	SK-4	Ø3-Ø95	Ø29-Ø84	59	Ø24	Ø24	16
	SK-5	Ø3-Ø110	Ø33-Ø100	60	Ø32	Ø28	16
AR / RC-170	SK-6	Ø4-Ø160	Ø55-Ø150	67	Ø45	Ø30	16
	SK-7	Ø8-Ø180	Ø62-Ø170	76.5	Ø58	Ø30	16
AR / RC-210(H) AR / RC-250(H)	SK-7	Ø8-Ø180	Ø62-Ø170	76.5	Ø58	Ø30	16
	SK-8	Ø8-Ø190	Ø68-Ø180	76.5	Ø58	Ø30	16
HI / HR / RC-255 HI-320	SK-9	Ø11-Ø220	Ø70-Ø210	84	Ø70	Ø70	20
	SK-10	Ø12-Ø260	Ø80-Ø250	87	Ø89	Ø70	20
HR / RC-320	SK-9	Ø11-Ø220	Ø70-Ø210	84	Ø70	Ø70	20
	SK-10	Ø12-Ø260	Ø80-Ø250	87	Ø89	Ø89	20
HR / RC-400	SK-12	Ø15-Ø300	Ø90-Ø290	96	Ø105	Ø105	25
HI-400	SK-12	Ø15-Ø300	Ø90-Ø290	96	Ø105	Ø70	25
	SK-16	Ø30-Ø380	Ø110-Ø350	122	Ø160	Ø70	25
HI-500	SK-16	Ø30-Ø380	Ø110-Ø360	122	Ø160	Ø160	25
	SK-20	Ø125-Ø460	Ø25-Ø480	140	Ø205	Ø205	25
HR-500	SK-20	Ø125-Ø460	Ø25-Ø480	140	Ø205	Ø205	25
	SK-25	Ø198-Ø601	Ø80-Ø630	140	Ø275	Ø270	28

※ Note: After the chuck grips the workpiece, if the protruding jaws cause the rotation radius to exceed the center height of the rotary table, a riser block must be installed to prevent the jaws from interfering with the machine table. (Unit : mm)

### Servo Motor Reference Table (Please use oil-proof motors)

The data in the CNC rotary table specification sheet are calculated based on FANUC aiF servo motors. If other brands of servo motors are employed, please refer to the below list in order to select the suitable non-Fanuc servo motors whose sizes and features are similar to assigned Fanuc aiF ones. But, the below list is not suitable for the rotary axis of FAR-100/160SN and FAR-170A. Please consult with TJR to confirm the model of servo motor while placing order.

FANUC	aiF2 / 5000 aiS4 / 4000 BiS4 / 4000	aiF4 / 4000 aiS8 / 4000 BiS8 / 3000	aiF8 / 3000 aiS12 / 4000 BiS12 / 3000	aiF12 / 3000 aiS22 / 4000 BiS22 / 2000	aiF22 / 3000 aiS22 / 4000 aiS40 / 4000	aiF40 / 3000 aiS40 / 4000 aiS60 / 4000
MITSUBISHI	HF-75T / HG75T	HF-54T / HG104T	HG154S	HF-204S / HG204S	HF-354S / HG354S	HF-703S
YASKAWA	SGM7J-08A	SGM7G-09A	SGM7G-13A SGM7G-20A	SGM7G-30A	SGM7G-30A SGM7G-44A	SGM7G-44A
SIEMENS	1FK7042	1FK7060	1FK7063	1FK7083	1FK7101	1FK7103 / 1FK7105
HEIDENHAIN	QSY-96A	QSY-116C	QSY-116E QSY-130C	QSY-155B	QSY-155D	QSY-190D
SYNTEC	AM3-60	AM5-40	AM8-40 AM11-40	AM18-40	AM28-40	AM35-20(Ø35)

※ The servo motor models of the above list are actually categorized by motor sizes from the perspective of installation on the rotary tables. However, please do check the compatibility of servo motor based on the specification of NC control on the machining center.

※ Please employ higher torque motor while using connection plates and fixtures with support table.



## Accessories Series

**Air Hydraulic Booster Unit :**  
Timing for applications  
1. Use hydraulic brake rotary table + rotary tailstock  
2. Use hydraulic brake rotary table + manual tailstock

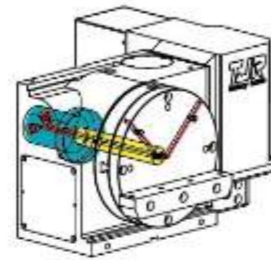

**Application diagram - rotary joint pneumatic / hydraulic distributor**  
When mounting pneumatic/hydraulic fixtures, please use rotary joint and disc L-blocks equipped with air/oil holes so that the air/fluid can go through the center-through hole to avoid intertwining while the rotary table spins.  
*(The standard operating pressure is below 70 MPa. Please inform us in advance if the pressure exceeds this range.)*

**Hydraulic Power Unit :**  
Timing for applications  
1. Use hydraulic brake rotary table + rotary tailstock  
2. Use hydraulic brake rotary table + rotary tailstock + hydraulic fixtures



**Pneumatic / Hydraulic rotary joint :**  
(can be equipped with 2, 4, 6, 8 holes)  
**2 holes :** 1 input ; 1 output  
**8 holes :** 4 input ; 4 output



Separated wiring of adaption and connection for power cable and feedback cable respectively.  
\* As shown in the right diagram, internal cables include:  
No. ① - ② power cable  
No. ⑦ - ⑧ feedback cable  
7 I/O signals for rotary table  
\* TJR can also provide :  
③ - ⑥ and ⑨ - ⑫ cables

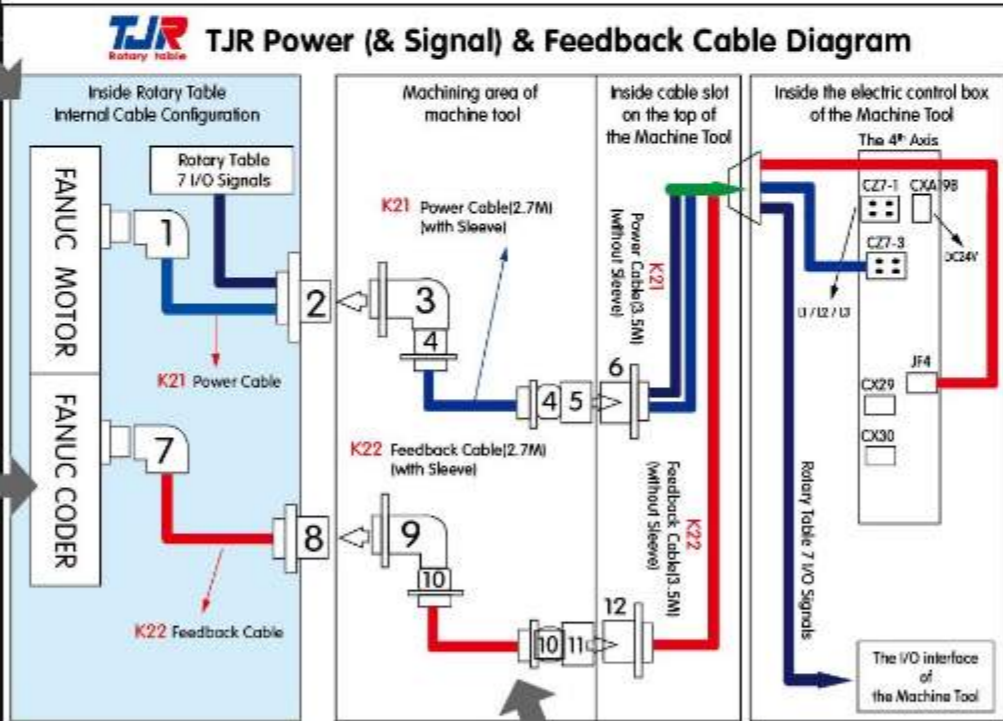

**Cable assembly the customer provide (Optional)**

(A) No hole and cable  
(B) Direct wiring of power cable and feedback cable combined into one  
(C) Direct wiring of power cable and feedback cable combined into one  
(D) Wiring of adaption and connection for combined power cable and feedback cable

If you prefer any one of the above-mentioned types of cable assembly, we will provide only the rotary table [ 7 (air brake) ] I/O signal connector. You need to prepare the rest.

**Cables located inside machining area of machine tool.**

Feedback cable (⑨, ⑪)  
Power (& signal) cable (⑤)

Take Heidenhain for example

Heidenhain model of angle encoder	Fargor model of angle encoder	Angle encoder accuracy	Rotary table accuracy	
			C axis	A axis
ECN-2190F (FANUC)	H2AF-23-D87	± 10"	-	Within 30"
ECN-2190M (MITSUBISHI)	H2AM-23-D87			
ECN-2110 (SIEMENS)	H2AD-23-D87 H2AD-23-D87+EC-PA-DQ1 <i>don't need SMC-20</i>			
RCN-2391F (FANUC)	H2AF-26-D90	± 4"	Within 10"	Within 20"
RCN-2391M (MITSUBISHI)	H2AM-26-D90			
RCN-2311 (SIEMENS)	H2AS-26-D90 H2AD-26-D90+EC-PA-DQ1 <i>don't need SMC-20</i>			
RCN-2591F (FANUC)	H2AF-28-D90-2	± 2"	Within 8"	Within 15"
RCN-2591M (MITSUBISHI)	H2AM-28-D90-2			
RCN-2511 (SIEMENS)	H2AS-26-D90-2 H2AD-26-D90-2+EC-PA-DQ1 <i>don't need SMC-20</i>			
RCN-8391F (FANUC)	H2-AF-29-D2001100-2	± 2"	Within 6"	-
RCN-8391M (MITSUBISHI)	H2-AM-29-D2001100-2			
RCN-8311 (SIEMENS)	H2-AS-29-D2001100-2			

\* Not any rotary table can be equipped with above-mentioned angle encoder. Please check the compatibility between rotary table and angle encoder with TJR after rotary table model is confirmed.

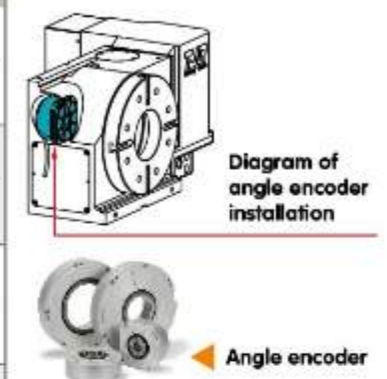

Accuracy comparison sheet while using angle encoder

### 1 Spindle bearings strength

TJR	Others	Others
Radial & axial preloading bearing	Taper roller bearing	Cross roller bearing
Large diameter	Small diameter	Small diameter
Suitable for for <b>heavy-duty cutting</b> in the horizontal and vertical directions.	Only suitable for <b>light cutting</b>	Only suitable for <b>light cutting</b>



Laser measuring equipment (Indexing precision testing)

### 2 Advanced inspection facilities



3D measuring equipment Geometry precision testing



Optional Accessories

Optional Accessories

### Geometry Precision Test Standard of Rotary Table (Unit : mm)

AR / HR  
(single axis)

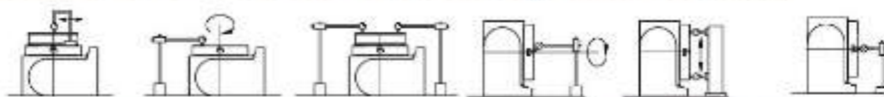

Inspection Items	Flatness of table top (Lower in the center) Total Length	Runout of table top during rotation Per 300 mm	Parallelism of table top to frame bottom Total Length	Runout of table central hole Front	Perpendicularity of table top to frame bottom Total Length	Perpendicularity of table top to frame bottom guide blocks Total Length	Indexing Precision (Measured by optical instrument) Accumulative tolerance	Parallelism of centerline between rotary table and tailstock frame bottom guide blocks	Height Difference between Center Line of Rotary Table and that of tailstock (tailstock center line should be higher)
ARs-125	0.01	0.015	0.02	0.01	0.01	0.02	40"	0.02	0.02
AR-170(H) / 210(H) / 250(H)	0.01	0.015	0.02	0.01	0.01	0.02	20"	0.02	0.02
AR-170(HB)/210(HB)/250(HB)	0.01	0.015	-	0.01	0.01	0.02	20"	0.02	0.02
HR-255 / 320 / 400	0.015	0.015	0.02	0.01	0.01	0.02	15"	0.02	0.02
HR-500	0.02	0.015	0.02	0.01	0.02	0.02	15"	0.02	0.02
HR-630 / HR-800	0.03	0.02	0.03	0.01	0.03	0.03	15"	0.02	0.02

FHR  
(dual axes)



Inspection Items	Flatness of table top (Lower in the center) Total Length	Runout of table top during rotation Per 300 mm	Parallelism of table top to frame bottom Total Length	Runout of table central hole Front	Parallelism between center line of filling axis and bottom Total Length	Tilt axis - indexing precision (seconds)	Rotary axis - indexing precision (seconds) Accumulative tolerance	Parallelism between rotary table and positioning block of bottom
FARs-125	0.015	0.015	0.02	0.01	0.02	60"	40"	0.02
FAR-170 / 210	0.015	0.015	0.02	0.01	0.02	60"	20"	0.02
FHR-255	0.015	0.015	0.02	0.01	0.02	60"	15"	0.02
FHR-320 / 400	0.015	0.015	0.02	0.01	0.02	60"	15"	0.02
FHR-500	0.02	0.015	0.02	0.01	0.02	60"	15"	0.02
FHR-650	0.02	0.015	0.02	0.01	0.02	60"	15"	0.02
MTHR-255	0.02	0.02	0.02	0.01	0.02	-	15"	0.02

HRC  
Swivel (Spindle) Head

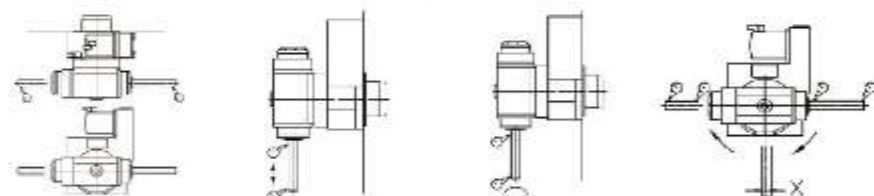

Inspection Items	pindle center to mounting surface parallelism (+90° to -90°) Per 150 mm	Spindle center to mounting surface parallelism (0°) Per 150 mm	Spindle runout at spindle center Per 150 mm	Offset between spindle center and rotary axis center (value X)	Cumulative indexing accuracy (measured by optical instrument) Accumulative tolerance
HRC-400SP	0.022	0.01	0.01	0.008	20"

Standard Clamping device

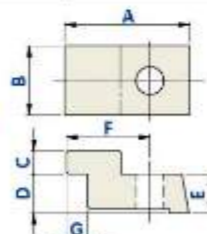

Examples of special clamping device

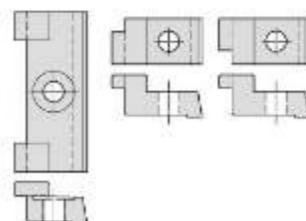

#### Specification Clamping device

Model	Standard Clamping Device						
	A	B	C	D	E	F	G
ARs-125	63	35	12	20	20	43	11
AR-170(H)	78	40	12	25	22	49	11
AR-210(H)	78	40	12	25	22	49	11
AR-255H	78	40	12	25	22	49	11
HR-255	78	40	12	25	22	49	11
HR-320	78	40	15	35	25	49	11

Model	Standard Clamping Device						
	A	B	C	D	E	F	G
HR-400	78	40	15	35	25	49	11
HR-500	63	60	18	40	58	33	18
HR-630	63	60	18	40	58	33	18
HI-255	78	40	12	25	22	49	11
HI-320	78	40	15	35	25	49	11
HI-500	63	60	18	40	58	33	18

### Rotary angle measurement of rotary table

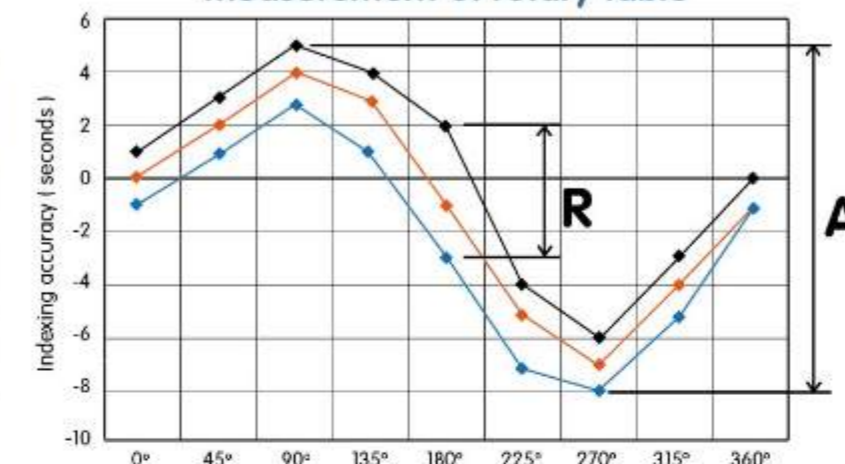

### The measurement of ISO 230-2

#### Indexing Precision

Rotate the axis in one direction and measure all the indexing values at equally divided and fixed angles (including at least 0°, 90°, 180°, 270°). Take the summary of the maximum positive difference and the maximum negative difference (absolute value) of all the measured values.

#### Repeatability

Repeatedly rotate the axis in one direction and measure all the indexing values at equally divided and fixed angles (including at least 0°, 90°, 180°, 270°). Get the maximum differences of all measured indexing values at each fixed angle. Then, pick the biggest values from the measured maximum differences of all angles.



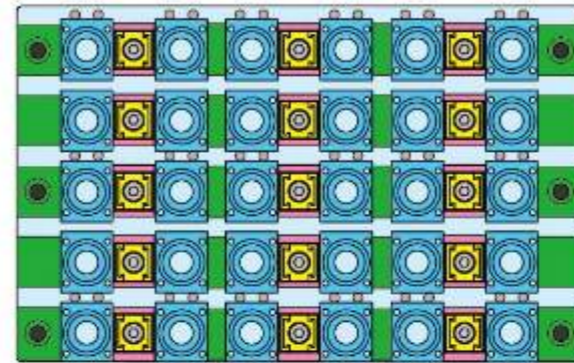

## Little King Kong Vise

▶ **Little King Kong Vise**  
An example of fixing round work-piece.

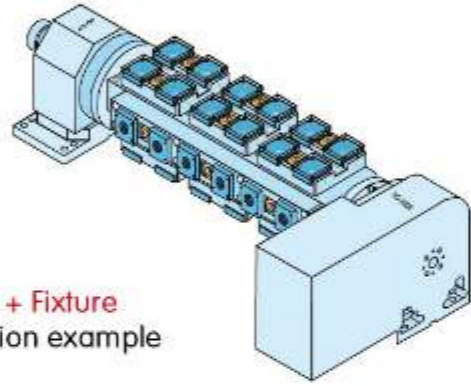

- **Blue:** Work-piece
- **Yellow:** Little King Kong Vise
- **Green:** Work-holding fixture
- **Pink:** Vise directional fixture

▶ **The 4<sup>th</sup> axis + Fixture**  
An application example

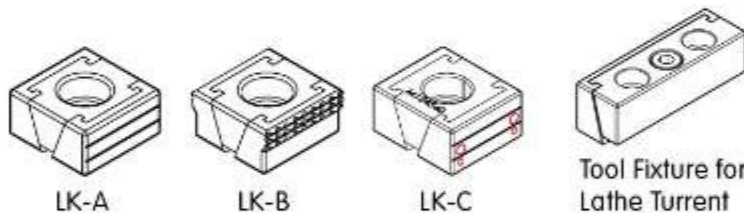

▶ Zero point clamping system is available.  
High-precision exchange of clamping devices, fixtures and work-pieces within seconds.

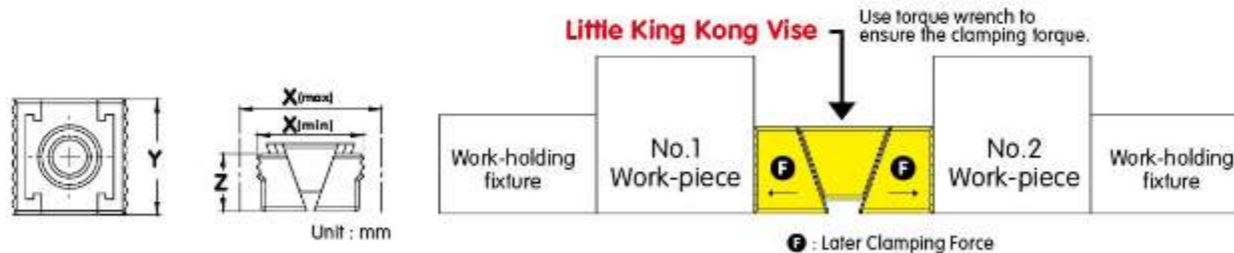

Vise specification	Model	Vise dimension				Suitable Screw	ⓐ Clamping Force (KN)	Surface Hardness (HRC)	
		X (mm)			Z (mm)				
		Min.	Rated	Max.					
	M062525	23	25	26	25	12	M6*16	18	48-52
	M083030	27	30	31	30	15	M8*20	25	48-52
	M104040	36	40	42	40	20	M10*25	45	48-52
	M124540	40	45	47	40	22	M12*30	65	48-52
	M166060	54	60	63	60	29	M16*40	110	48-52

## Zero Point Clamping System

A modern solution to replace traditional T-slot tables

Zero point clamping system is the modern alternative to the conventional T-slot table: Drastically reduces the setup times and increases your machine capacity.



Make your own work-holding fixture by easily employing TJR Vise and TJR zero point clamping system on the fixture plate of 4<sup>th</sup> axis or the faceplate of 4<sup>th</sup> & 5<sup>th</sup> axes. Holes on the zero point clamping system are used as sockets for clamping studs. (For detailed dimensions, please contact us.)

Benefit Analysis				
Benefits after the introduction of the mold change system				
Work time per week	400 hours (2400 mins)	Number of mold changes	Before	After
			2 hours (120 mins)	
Number of mold changes	4 times	Saving time per year	460 mins	
Saving time per year	23,920 mins	NTS 6 for one minute	NTS143,520	

Work-holding fixture can be changed quickly and accurately (across all machines).

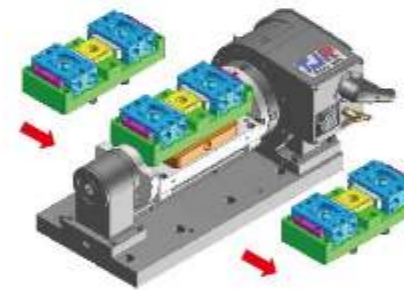

The illustration of the applicator for the 4<sup>th</sup> axis + connection plate



The zero point clamping system on the connection plate

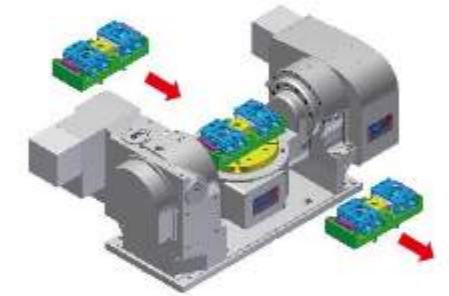

The illustration of the application for the zero point clamping system on the faceplate of the 4<sup>th</sup> & 5<sup>th</sup> axes

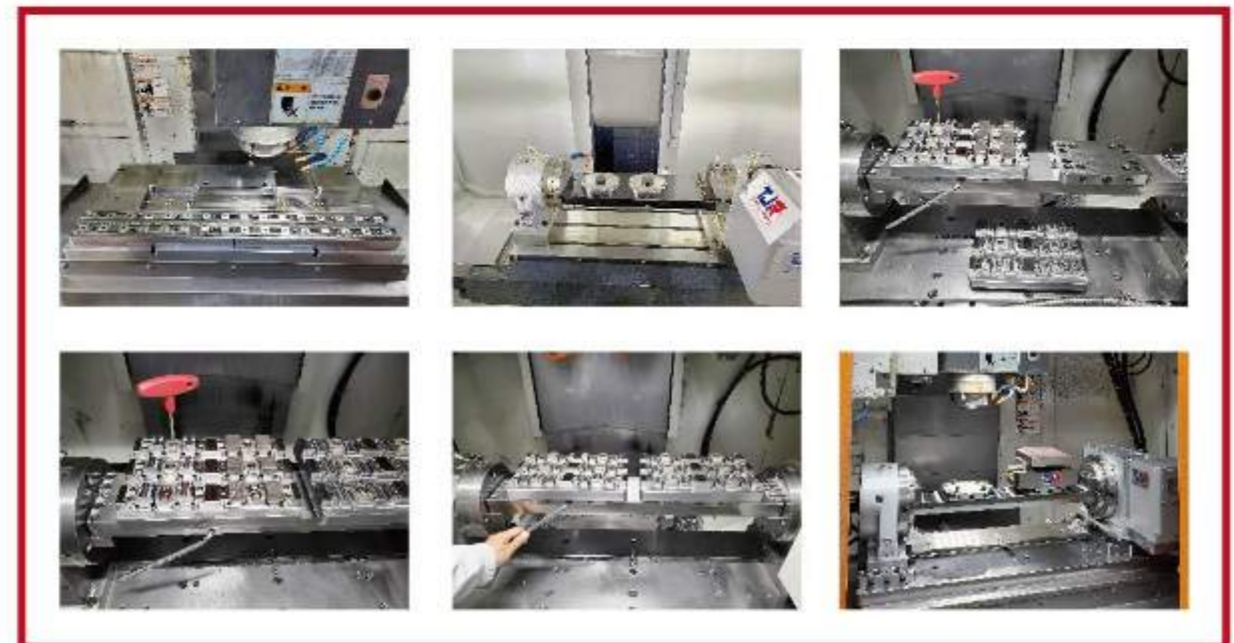

### Flow Chat of the Additional Axis Control

#### Applicable to the **RC** and **FRC** series models

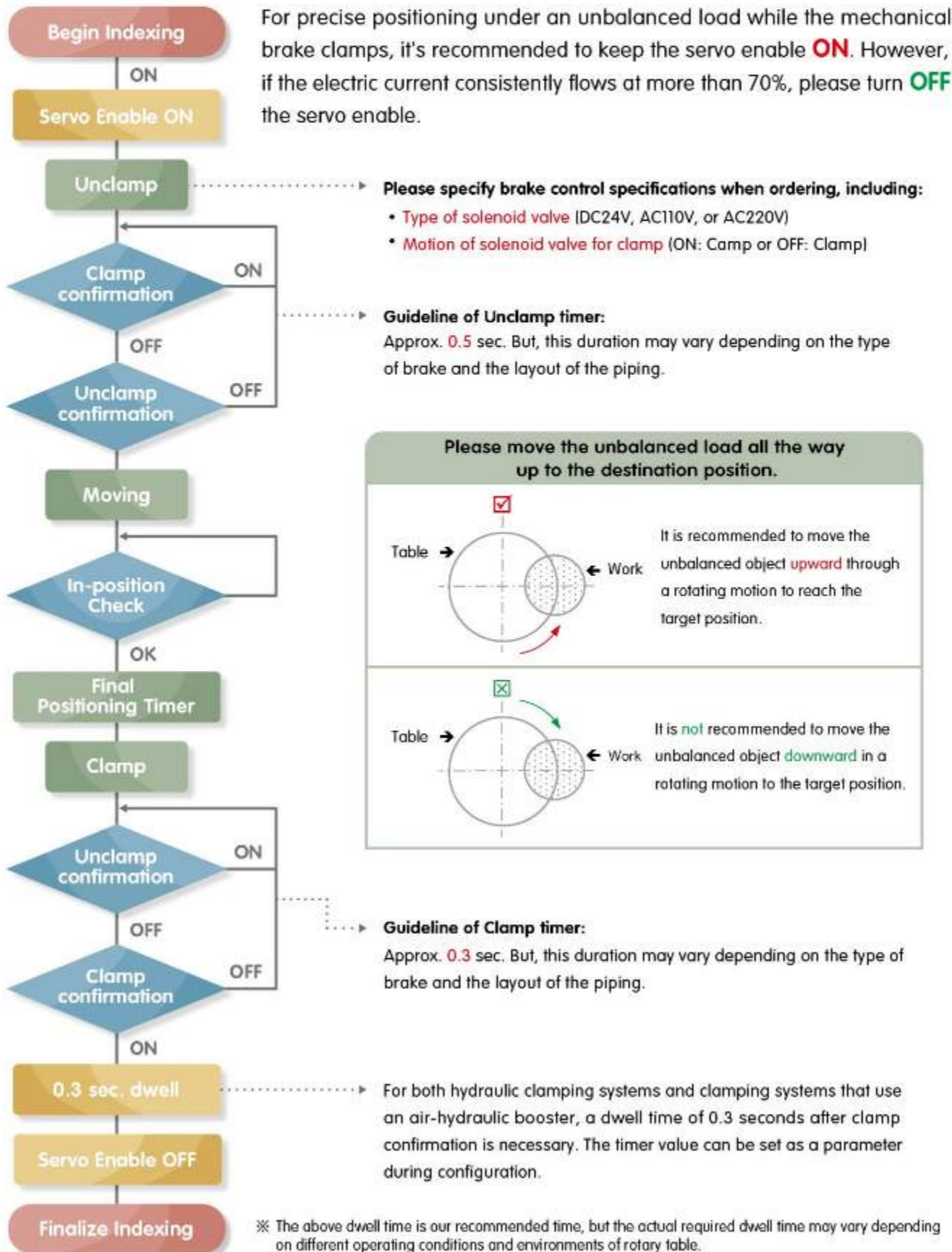

### Flow Chat of the Additional Axis Control

#### Applicable to the **AR, HR, HI, FAR, and FHR** series

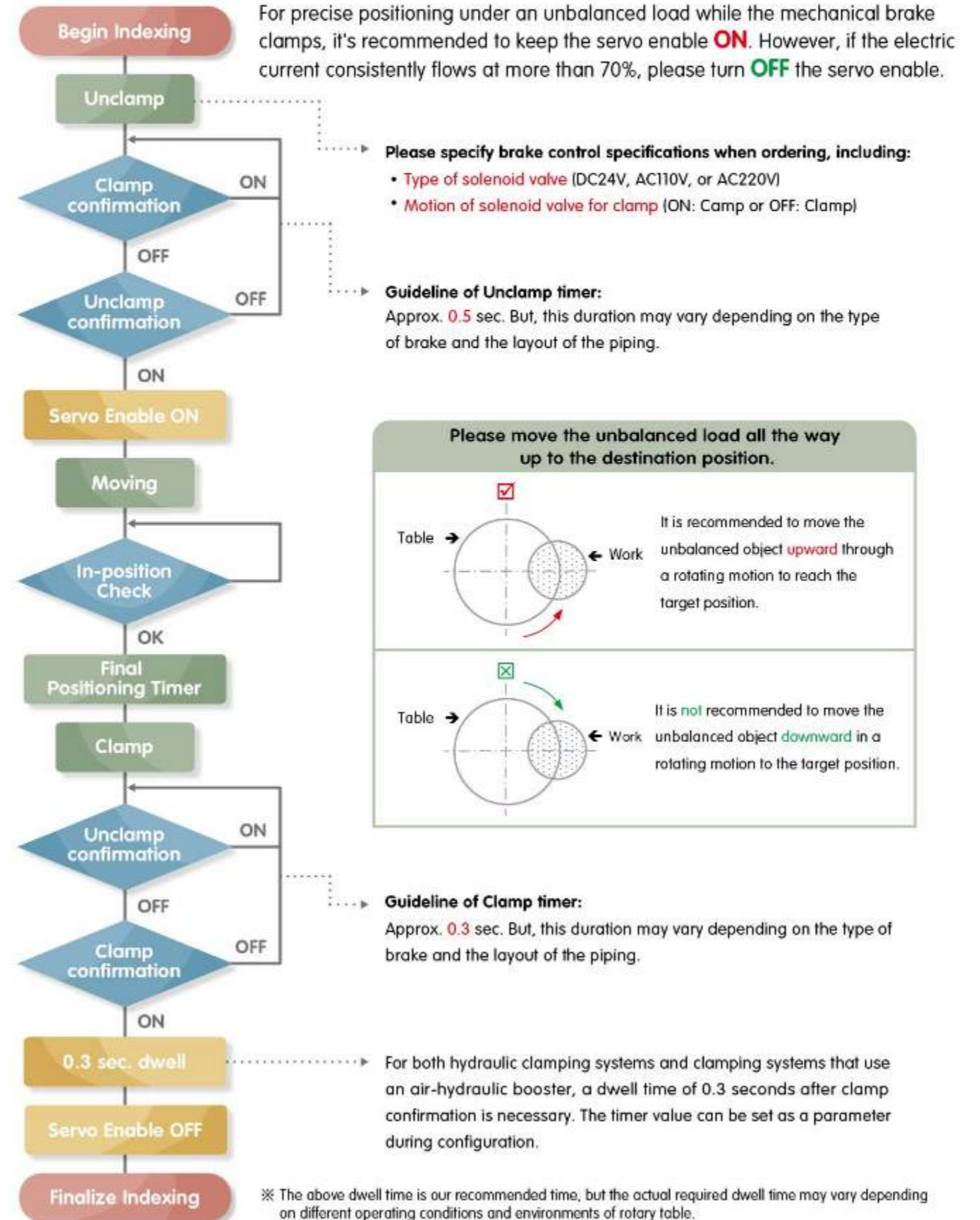



▲ EMO Hannover, Germany



▲ TIMOS Taipei, Taiwan



▲ JIMTOF Tokyo, Japan



▲ TES Shenzhen, China



▲ CME Shanghai, China

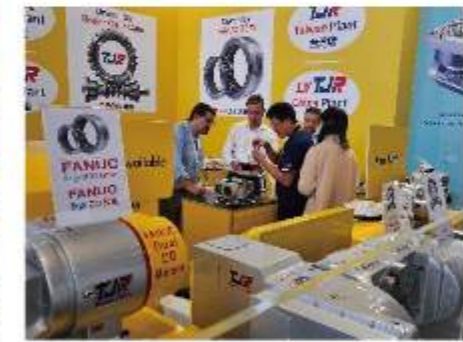

Examples of applications: TJR can work with all brands of control systems and machines.

