



TJR APP -
Android



TJR APP -
iOS



www.tjr.com.tw

Product Code

AR - 210 - H R - J - A

Ø210mm



Table Diameter

Ø255mm



Special Version (A, B, C,...)
Specified by Customers

Worm & Gear material

Refer to page2 Table1

J High Tensile Brass

T Aluminum Bronze

Alternative Hydraulic Brake

Except for AR-255H
Refer to page2 Table3

Motor mounting location

Refer to page2 Table2

R Right Mount

B Back Mount

L Left Mount

N Right Mount

with sheet metal cover reduction

Model Code (by Transmission Mechanism)

AR HR Series



Worm & Worm Gear

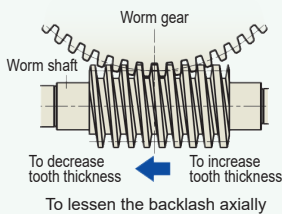

Specially designed double-lead worm & gear with full-depth teeth. The worm gear with a large pitch diameter creates a large engagement area and less pressure on the contact surface, resulting in higher strength. By moving the worm shaft axially, the tooth engagement can be changed successively. As the backlash between worm and gear can be adjusted while keeping them in their proper positions, the ideal tooth engagement is maintained.

RC Series



Roller Gear Cam

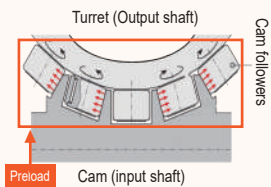

It consists of an input shaft and output turret with embedded roller followers. A cross-roller bearing supports the output turret with minimal run out and transmits power by rolling rather than sliding. Preloaded roller followers contact the input rib surfaces with a wedge-shaped cross section. It can be adjusted by moving the input axis, eliminating backlash completely. Clearly seen for CW and CCW rotation.

AD Series



Direct Drive Motor

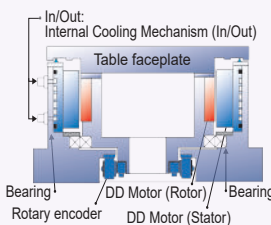

There is no mechanical transmission (reduction) mechanism such as worm gear or roller cam system in a rotary table equipped with a D.D. (Direct Drive) motor. The torque (Direct Drive) motor is built in the rotary table to drive directly. High rotation speed and high acceleration / deceleration can be achieved. Besides, a built-in rotary encoder is employed to secure high positioning and repeatability.

The sales of different models by major industry sector

Industry Sector

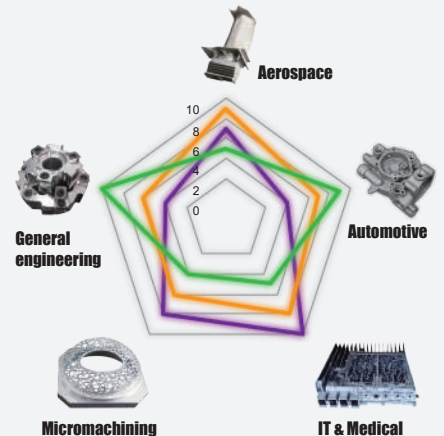

Transmission Mechanisms

- Worm & Worm Gear **AR HR**
- Roller Gear Cam **RC**
- Direct Drive Motor **AD**

Product Features

Features of different Transmission Mechanisms

Table 1

Model	Ø210mm	AR-210-T	AR-210-J	RC-210	—
	Ø255mm	HR-255-T	HR-255-J	RC-255	AD-261IB
Transmission Mechanism	Worm & Worm Gear		Roller Gear Cam		Direct Drive Motor
Material	Worm wheel : T Aluminum Bronze		Worm wheel : J Special high tensile brass		Turret, Roller Gear Cam, and Follower : Case hardened alloy steel
	Worm shaft : Case hardened alloy steel		The table runs on a series of rollers, meaning slick rolling surface operation with no backlash and wear.		FANUC Specially Customized Synchronous Built-in torque motor A perfect match for Fanuc control. The risk of damage is minimized when an improper operation occurs.
Compact Footprint	—	—	—	—	★★★★
Zero Backlash	—	—	—	★★★★	★★★★
Anti-Wear	★	★★	★★★	★★★★	★★★★
Maintenance	★	★	★	★★	★★★★
Rotary Speed	★	★	★	★★	★★★★
Indexing Precision / Repeatability	★★	★★	★★	★★	★★★★
Loading capacity	★★★	★★★★	★★★★	★★★★	★★
Driving Torque (without Brake)	★★★	★★★★	★★	★★	★
Popularity	★★★	★★★★	★★★★	★★	★

★★★★ Excellent ★★★ Good ★ Neutral

Motor Mounting Location

Table 2

Positioning	Code	R Right Mount	L Left Mount	N Right Mount with sheet metal cover reduction	B Back Mount
Diagram					
VERTICAL 		✓	✓	✓	✓
HORIZONTAL 		✓	✓	✗	✗

Model Name by brake mechanism

Table 3

Brake type	Faceplate size	Ø210mm		Ø255mm	
Air brake		AR-210	RC-210	AR-255H	NA
Oil brake		AR-210H	RC-210H	HR-255	RC-255
					AD-261IB
					NA

Ø210, 255mm Models

Specifications



Air brake



Oil brake

Transmission mechanism		Unit	Worm & Gear	Roller Gear Cam	Worm & Gear	Roller Gear Cam	Direct Drive Motor
Model		-	AR-210 *1	RC-210	AR-255H HR-255	RC-255	AD-261IB
Faceplate diameter		mm	Ø210 *1	Ø210	Ø255	Ø255	Ø250
Inner Diameter of Mandrel Sleeve		mm	Ø40H7	Ø40H7	Ø80H7	Ø80H7	Ø46H7
Diameter of Center Through Hole		mm	Ø40	Ø40	Ø80	Ø80	Ø46
Center Height (Vertical)		mm	160	160	160	160	160
Table Height (Horizontal)		mm	152 160 *2 NA *3,4	152 185 *2	200	200	NA
Table T-slot Width		mm	12H7	12H7	12H7	12H7	12H7
Guide Block Width		mm	18h7	18h7	18h7	18h7	18h7
Min. Increment		deg.	0.001	0.001	0.001	0.001	0.001
Indexing Precision		sec.	20	30	15	20	20
Repeatability		sec.	6	6	6	6	4
Clamping System		kgf/cm ²	Pne. 6 / Hyd. 35	Pne. 6 / Hyd. 35	Pne. 6 Hyd. 35	Hyd. 35	Pne. 6
Clamping Torque		kgf-m	31 / 55	31 / 50	70 70	70	45.9
Servo Motor Model	FANUC	-	aiF8 / βiS8	aiF8 / βiS8	aiF8/βiS12	aiF8/βiS12	FANUC DD Motor
	MITSUBISHI	Taper/Straight shaft	HG-54 / 104	HG-54 / 104	HG -154	HG -154	-
	SIEMENS	-	1FK7060	1FK7060	1FK7063	1FK7063	-
	HEIDENHAIN	-	QSY-116C	QSY-116C	QSY-116E	QSY-130C	-
Speed Reduction Ratio		-	1 : 90	1 : 36	1 : 120	1 : 60	Direct Drive
Max. Rotation Rate of Table (Calculate with Fanuc a Motor)		min-1	44.4	83.3	33.3	50	200 (Rated) 300 (Max.)
Allowable inertia load capacity (Horizontal)		kg-m ²	0.63	0.63	1.2	1.2	1.2
Allowable Workpiece Load	Vertical	kg	75	75	100	100	100 *5
	With Tailstock	kg	150	150	250	250	100 *5
	Horizontal	kg	150 / NA *3,4	150	250	250	-
Allowable Thrust Load (with Rotary Table Clamping)	F	kgf	1450	1450	2000	2000	1020
	FxL	kgf-m	110	110	150	150	23.6
	FxL	kgf-m	31 / 55	31 / 50	70	70	45.9
Driving Torque		kgf-m	37	37	55	55	-
Net Weight (servo motor excluded)		Kg	55 58 *2 65 *3 72 *4	52 62 *2	118 109	110	90
Optional Rotary Joint 		Available Number of Ports	2,4	2,4	2,4,6,8	2,4,6,8	2,4

*1: The faceplate can be enlarged to Ø250 as an option.
 *2: When the faceplate is enlarged to Ø250 and motor mount location is LEFT or RIGHT.
 *3: When the faceplate is Ø210 and motor mount location is BACK.
 *4: When the faceplate is enlarged to Ø250 and motor mount location is BACK.
 *5: Valid when it is below the rated speed.

Ø210mm Model Dimensions

RC-210R

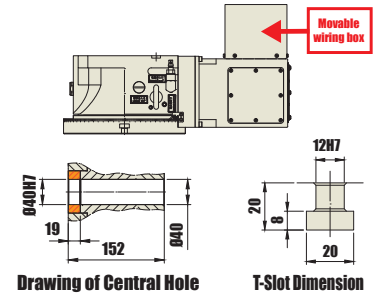
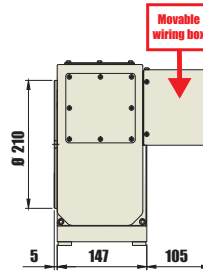
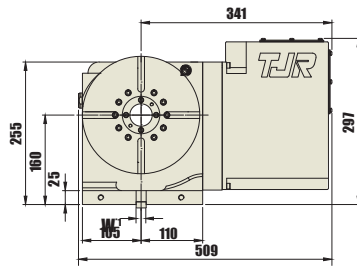

RC-210L

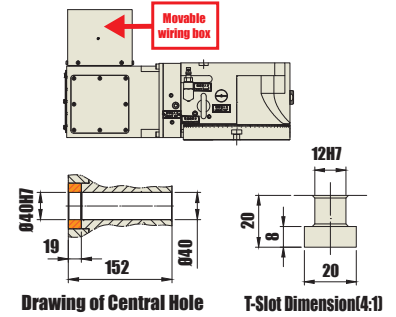
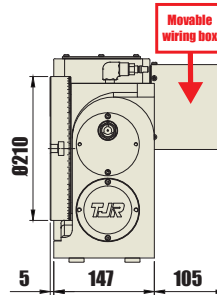
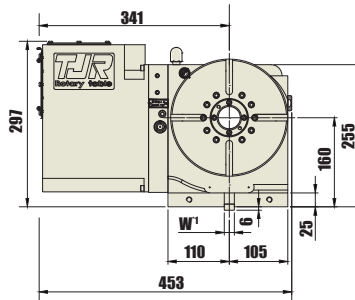

AR-210R

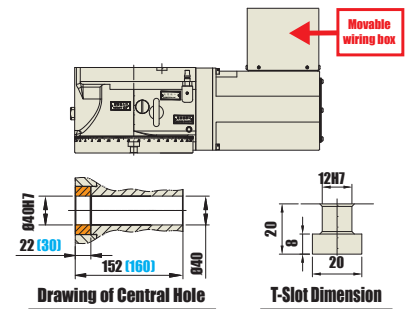
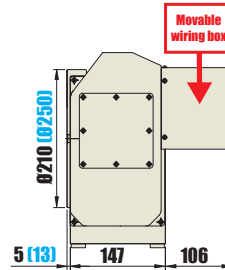
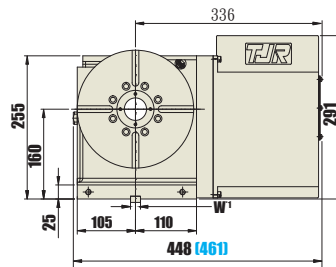

(): When the faceplate is enlarged to Ø250mm.

AR-210L

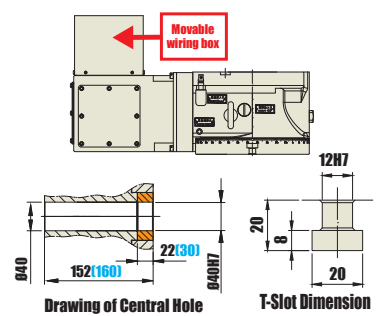
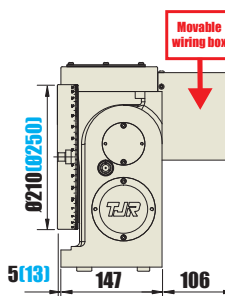
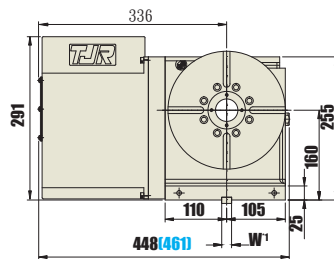

(): When the faceplate is enlarged to Ø250mm.

AR-210B

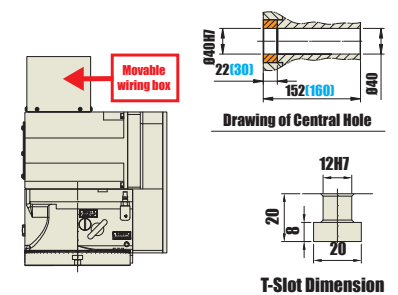
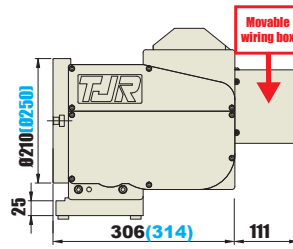
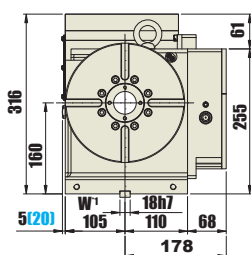

(): When the faceplate is enlarged to Ø250mm.

*1: The Guide Key size can be changed based on the T-slot of work table.

★ Air purge function is provided inside the motor cover as standard.

★ External dimensions depend on the type of the servo motor. Indicated dimensions are in case of FANUC. Please contact us for CAD files.

Ø255mm Model Dimensions

AD-261iB

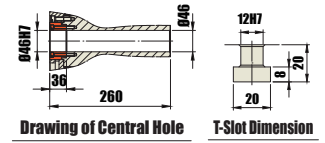
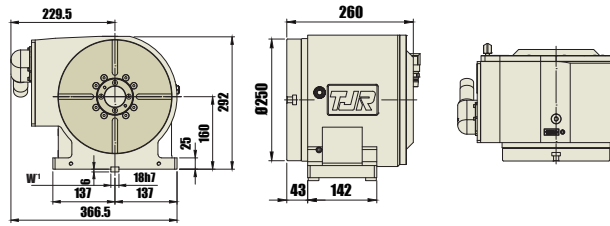

RC-255R

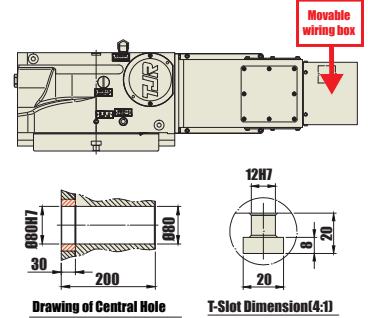
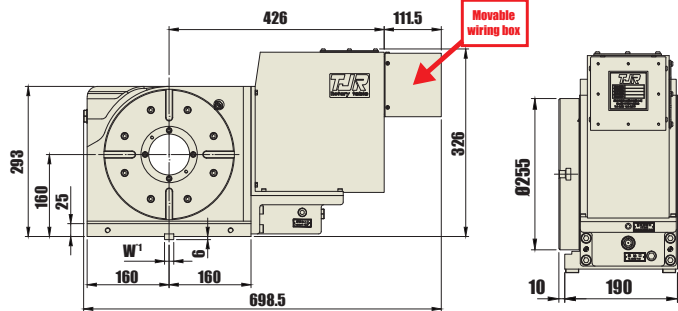

RC-255N

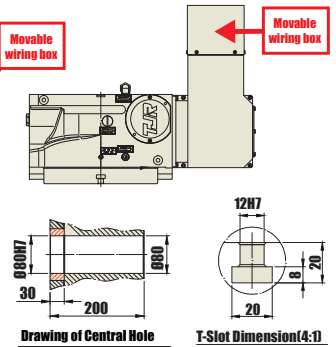
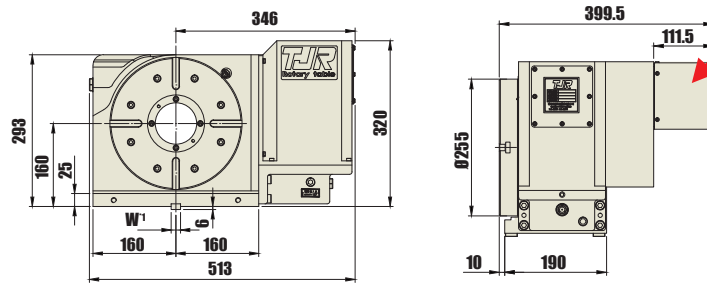

HR-255R

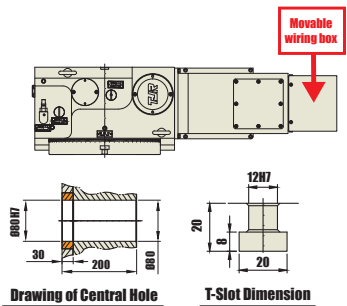
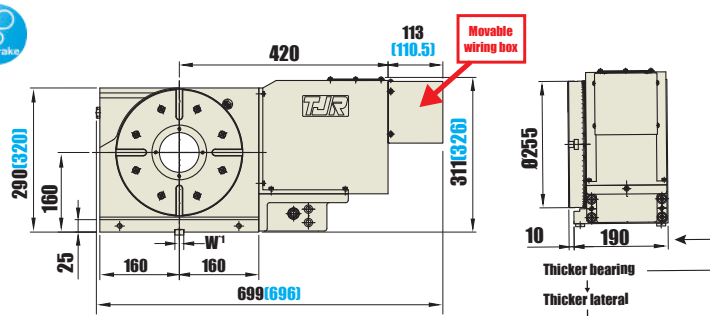

(): the dimension of Model AR-255HR

HR-255N

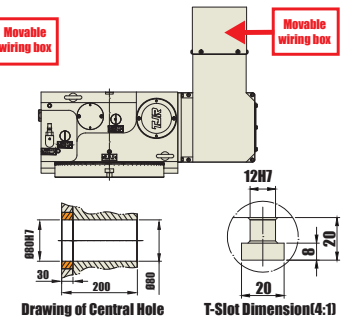
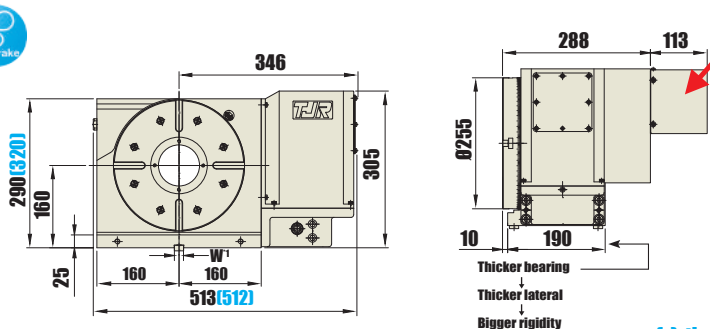

(): the dimension of Model AR-255HN

*1: The Guide Key size can be changed based on the T-slot of work table.

★ Air purge function is provided inside the motor cover as standard.

★ External dimensions depend on the type of the servo motor. Indicated dimensions are in case of FANUC. Please contact us for CAD files.

Support Table & Corresponding Accessories

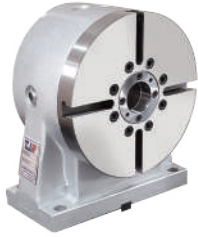

RTA-210 Air brake Oil brake



RTH-255 Oil brake



RT-210F No Brake

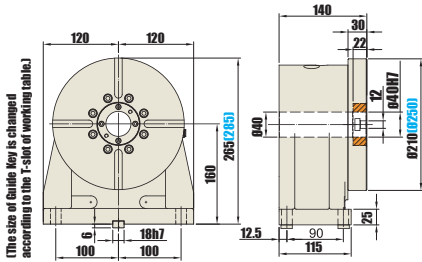

(): When the faceplate is enlarged to ø250mm. Weight : 35kg

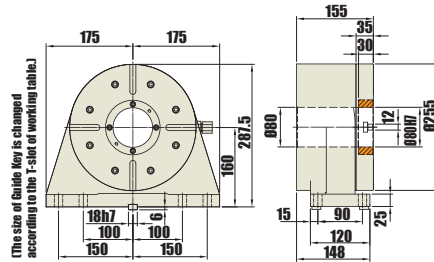

Weight : 57kg

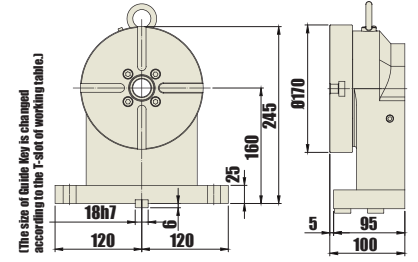

Weight : 36kg

Trunnion Application

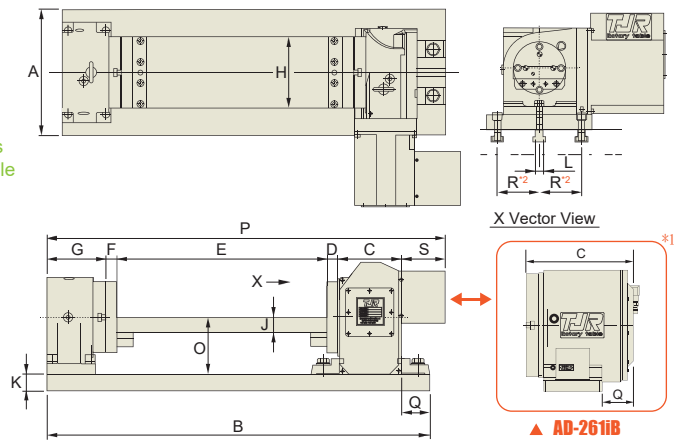
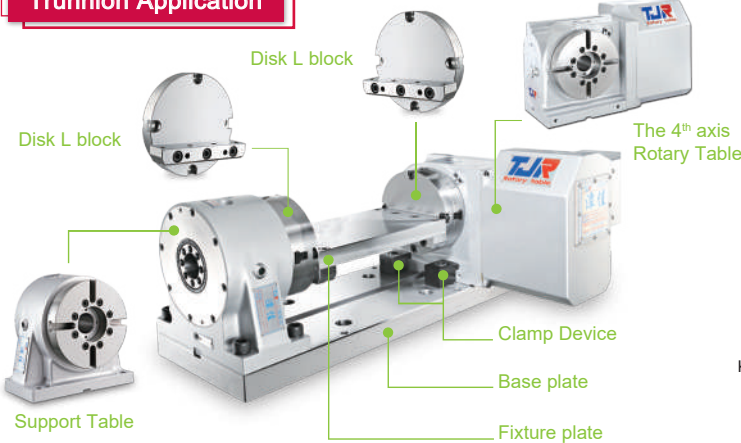

Rotary Table Model	Support Table Model	A	B	C	D	E	F	G	H	J	K	L	O	P	Q	S
AR-210 RC-210	RTA-210	300	1011	152	25	600	25	140	200	40	40	18	135	1047	69	105
HR-255 RC-255	RTH-255	350	1148	200	25	700	25	155	250	45	40	18	160	1306	69	201
AD-261iB*1	RTA-210	300	976	260	25	600	25	140	200	40	40	18	160	1065	NA*1	NA*1

*1: Due to the different structure of rotary table, the above dimensional drawing can not be fully applicable to AD-261iB. However, the figures of AD-261iB in the above sheet can be still referenceable. Please contact TJR for a precise drawing of AD-261iB when it's needed.

*2: "R" depends on the size of machine worktable.

★ A suitable raiser for either rotary table or manual tailstock can be customized to increase the center height.



▲ AR-250 + RTA-250

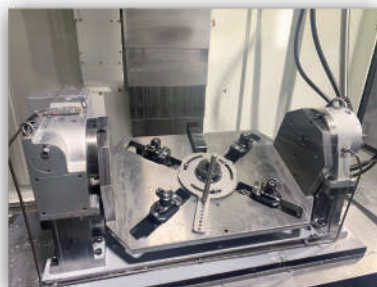

▲ RC-255 + RTH-255

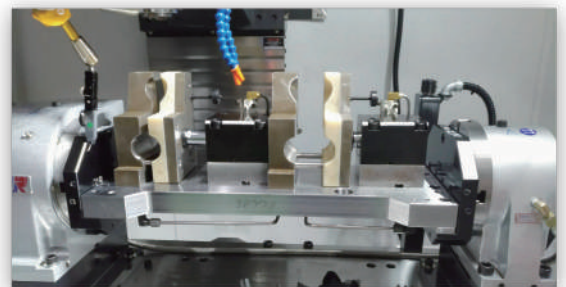

▲ AD-261iB + RTA-210

Manual Tailstock & Corresponding Accessories

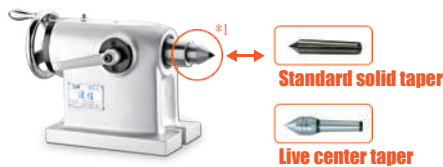

TTJ-210/255

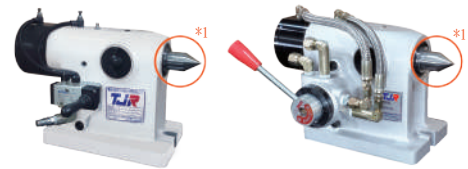
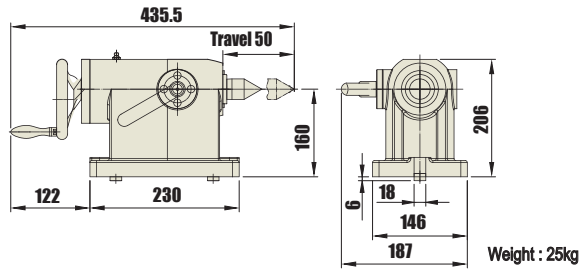

ATTJ-210/255
(With Pneumatic switching valve)

HTTJ-210/255
(With Hydraulic switching valve)

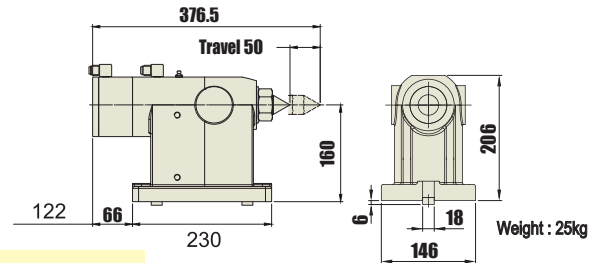

*1: The taper is replaceable. The standard one is a solid taper. Moreover, the live center taper can be optional.

Chuck and Tailstock Application

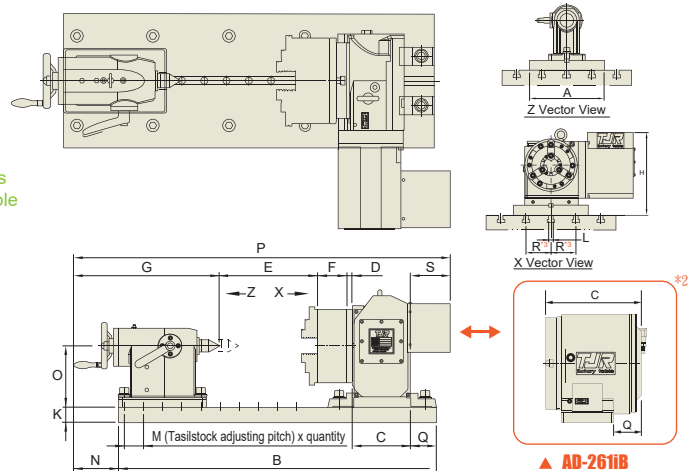
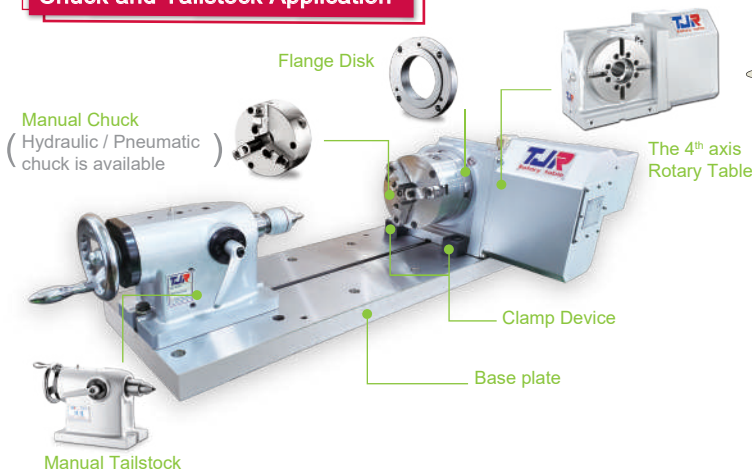

Rotary Table Model	Tailstock Model	Manual Chuck Model	A	B	C	D	E	F	G	K	N	O	P	Q	S
AR-210 RC-210	TTJ-210	SK-7	300	1011	152	16	437	76.5	382.5	40	122	160	1265	69	201
		SK-8	300	1011	152	16	437	76.5	382.5	40	122	160	1017	69	201
AR-255H HR-255 RC-255	TTJ-255	SK-7	350	1148	200	20	522	76.5	382.5	40	122	160	1402	69	201
		SK-8	350	1148	200	20	522	76.5	382.5	40	122	160	1202	69	201
		SK-9	350	1148	200	20	514.5	84	382.5	40	122	160	1202	69	201
AD-261iB ^{*2}	TTJ-255	SK-7					431	76.5							
		SK-8	300	976	260	20	431	76.5	381	40	NA ^{*2}	160	1168	NA ^{*2}	NA ^{*2}
		SK-9					423.5	84							

*2: Due to the different structure of rotary table, the above dimensional drawing can not be fully applicable to AD-261iB. However, the figures of AD-261iB in the above sheet can be still referenceable. Please contact TJR for a precise drawing of AD-261iB when it's needed.

*3: "R" depends on the size of machine worktable.

★ A suitable raiser for either rotary table or manual tailstock can be customized to increase the center height.



▲ AR-210 + TTJ-210

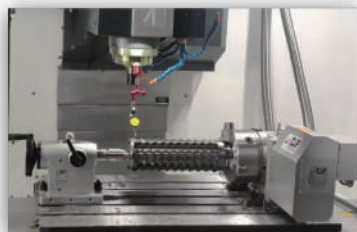

▲ RC-210 + TTJ-210



▲ AD-261iB + ATTJ-255